



INSTRUCTION MANUAL

MODEL 1140A THERMOCOUPLE SIMULATOR-CALIBRATOR

The information in this manual is proprietary and may not be reproduced without written permission from this company.

LIFE-SUPPORT POLICY: Ectron products are not authorized for use in life-support devices or systems without the express, written approval of the President of Ectron Corporation.

Copyright October, 2022
Ectron Corporation
All Rights Reserved

Ectron Corporation
9340 Hazard Way, Suite B2
San Diego, CA 92123
U.S.A.

858-278-0600
800-732-8159
Fax: 858-278-0372

E-mail: sales@ectron.com
Web site: www.ectron.com

WARRANTY

General

The Ectron Model 1140A is warranted against defects in material and workmanship for one year from the date of shipment. Ectron agrees to repair or replace any assembly or components (except expendable items such as fuses, lamps, batteries, etc.) found to be defective during this period. The obligation of Ectron under this warranty is limited solely to repairing or replacing, at its option, an instrument that in the sole opinion of Ectron proves to be defective within the scope of the warranty when returned to the factory or to an authorized service center. Transportation to the factory or service center is to be prepaid by the purchaser. Shipment should not be made without the prior authorization of Ectron. This warranty does not apply to products repaired or altered by persons not authorized by Ectron, or not in accordance with instructions furnished by Ectron. If the instrument is defective as a result of misuse, improper repair, alteration, neglect, or abnormal conditions of operation, repairs will be billed at Ectron's normal rates. Ectron assumes no liability for secondary charges of consequential damages as a result of an alleged breach of this warranty; and in any event, Ectron's liability for breach of warranty under any contract or otherwise shall not exceed the purchase price of the specific instrument shipped and against which a claim is made. This warranty is in lieu of all other warranties, expressed or implied; and no representative or person is authorized to represent or assume for Ectron any liability in connections with the sale of our products other than is set forth herein.

Procedure for Service

If a fault develops, notify Ectron or its local representative, giving full details of the difficulty. Include the model and serial numbers. On receipt of this information, a service date or shipping instructions will be furnished. If shipment is indicated, forward the instrument, freight prepaid, to the factory or to the authorized service center indicated in the instructions.

Damage in Transit

Instruments should be tested upon receipt. If there is any damage, a claim should be filed with the carrier. A full report of the damage should be obtained by the claim agent, and that report should be forwarded to Ectron. Ectron will advise the disposition to be made of the equipment and arrange for repair or replacement. Please include model and serial numbers in all correspondence.

Ectron Corporation
9340 Hazard Way, Suite B2
San Diego, CA 92123

Sales Department
858-268-0600, select option 1 for sales
sales@ectron.com

Technical Support Department
858-268-0600, select option 3 for technical support
support@ectron.com

TABLE OF CONTENTS

Warranty	After Title Page		
List of Tables	iv	Material	18
List of Figures	v	Thermocouple Type	20
Section I, Description		Message Displays	20
General	1	Menus	22
Changes Across Different Versions	2	Thermocouple Menu	23
Battery	2	Instrument Mode Menu	24
Remote Communications	2	Output Menu	25
Standby Mode and Temperature Shortcuts	2	Memory Menu	26
Terminal Alignment Corrections	2	Sequence Menu	28
About This Manual	2	Data Logging Menu and Downloading Data	30
Section II, Specifications		Display Menu	31
General	4	Remote Menu	32
Source Mode	4	Maintenance Menu	35
Thermocouple Output Mode	4	Diagnostics Menu	36
Voltage Output Mode	5	Section V, Applications	
Meter Mode	5	General	38
Supported Standards	5	Functions	38
General Instrument Specifications	5	Source Mode	38
Thermocouple-accuracy Tables	6	Meter Mode	38
Section III, Unpacking and Installation		Battery Operation	39
Shipment Contents	13	Connections	39
Unpacking	13	Thermocouple Connections	40
Model 1140A Installation	13	Temperature Variation	40
Driver Installation	13	Considerations	40
Packing for Shipment	13	Polarity of Thermocouple Wires	40
Section IV, Operation		Shielding and the Guard Terminals	41
General	15	Grounding	41
Front-panel Controls	15	ITS-90 and IPTS-68	41
Power	15	Offset	41
Menu Key	16	Autozero	42
Enter Key (Operate/Standby) ³	16	Low Output Impedance	42
Escape Key	16	Guard Bands	43
Twelve-key Keypad	17	Section VI, Remote Operation	
Four Arrow Keys	17	General	44
Encoder (Large Knob)	17	Remote Menu	44
Operating Screen Main Display	17	Activating and De-activating Remote Control	44
Control	18	Model 1140A Commands	46
Mode	18	Source-mode Commands and Queries	46
Offset	18	Meter-mode Query	47
Reference-junction Temperature	18	Thermocouple Commands and Queries	47
		Instrument Commands and Queries	49
		Output Commands and Queries	51
		System Commands and Queries	52
		Data Logging Queries	54

Model 1120 Remote Emulation Option	55	Source-mode Zero Alignment	66
Background	55	Meter-mode Zero Alignment	66
Limitations	55	LSB (Least-significant Bit) Alignment	66
Model 1120 Remote Control Operation	57	Meter-mode Sensitivity Alignment	67
Errors	58	Terminal Alignment	67
		Thermocouple Alloy Corrections (Optional)	68
Section VII, Theory of Operation		Section IX, Calibration	
Operating Modes	59	General	69
Thermocouple Simulator (Alloy Output)	59	Required Equipment	69
Precision Voltage Source (Copper Output)	60	Test Reports	69
Thermocouple Meter (Alloy Input)	60	Procedure	70
Precision Voltmeter (Copper Input)	60	Preliminary Setup	70
Thermocouple Simulator (Copper Output)	60	Linear-voltage-tests Setup	70
Thermocouple Meter (Copper Input)	60	Linear-voltage Tests in Source Mode	71
Precision Voltage Source (Alloy Output)	61	Linear-voltage Tests in Meter Mode	71
Precision Voltmeter (Alloy Input)	61	Thermocouple Voltage Tests	72
Thermocouple Offset	61	Thermocouple Alloy Tests	73
Hardware Implementation	62	Output-current Test	75
Firmware	62		
Front-panel Assembly	62	Appendix A, Calibration Test Reports	
Analog Assembly	62	Thirty-day Specifications, ITS-90	77
Optional Battery	63	Six-month Specifications, ITS-90	82
Power-supply Assembly	64	One-year Specifications, ITS-90	87
Section VIII, Alignment		Appendix B, Thermocouple Calibration	
General	65	Procedure	
Equipment Required	65	General	92
Preliminary	65	Equipment Required	92
Voltage Alignment	66	Procedure	92
DAC (Digital-to-analog Converter) Bit			
Alignment	66	Index	94
Divider Gain Alignment	66		

Table of Contents

LIST OF TABLES

Table 2-1: Type B Thermocouple (°C)	7
Table 2-2: Type B Thermocouple (°F)	7
Table 2-3: Type C Thermocouple (°C)	7
Table 2-4: Type C Thermocouple (°F)	7
Table 2-5: Type D Thermocouple (°C)	8
Table 2-6: Type D Thermocouple (°F)	8
Table 2-7: Type E Thermocouple (°C)	8
Table 2-8: Type E Thermocouple (°F)	8
Table 2-9: Type G Thermocouple (°C)	9
Table 2-10: Type G Thermocouple (°F)	9
Table 2-11: Type J Thermocouple (°C)	9
Table 2-12: Type J Thermocouple (°F)	9
Table 2-13: Type K Thermocouple (°C)	10
Table 2-14: Type K Thermocouple (°F)	10
Table 2-15: Type N Thermocouple (°C)	10
Table 2-16: Type N Thermocouple (°F)	10
Table 2-17: Type Platinel II Thermocouple (°C)	11
Table 2-18: Type Platinel II Thermocouple (°F)	11
Table 2-19: Type R Thermocouple (°C)	11
Table 2-20: Type R Thermocouple (°F)	11
Table 2-21: Type S Thermocouple (°C)	12
Table 2-22: Type S Thermocouple (°F)	12
Table 2-23: Type T Thermocouple (°C)	12
Table 2-24: Type T Thermocouple (°F)	12
Table 4-1: Thermocouple Types in the Model 1140A	19
Table 4-2: Default Settings	36
Table 6-1: Remote Command Summary	45
Table 6-2: Model 1140A Error Codes	53
Table 6-3: Model 1120 Remote Commands	58

LIST OF FIGURES

Figure 4-1: Front View of the Model 1140A	15
Figure 4-2: Main Menu	22
Figure 4-3: Thermocouple Menu	23
Figure 4-4: Instrument Mode Menu	24
Figure 4-5: Output Menu	25
Figure 4-6: Memory Menu with No Saved Files	26
Figure 4-7: Memory Menu with Saved Files	26
Figure 4-8: Sequence Menu	28
Figure 4-9: Data Logging Menu	30
Figure 4-10: Display Menu	31
Figure 4-11: Remote Menu	32
Figure 4-12: Web Browser Using the Ethernet Interface	34
Figure 4-13: Maintenance Menu	35
Figure 4-14: Diagnostics Menu	36
Figure 6-1: Remote Menu	44
Figure 7-1: Model 1140A Block Diagram	59
Figure 7-2: Source-mode Operation Diagram	63
Figure 7-3: Meter-mode Operation Diagram	63
Figure 9-1: Initial Operating Screen for Voltage Tests	70
Figure 9-2: Setup for Source Tests	71
Figure 9-3: Setup for Meter Tests	71
Figure 9-4: Initial Operating Screen for Temperature Tests	72
Figure 9-5: Operating Screen for Thermocouple Alloy Tests	73
Figure 9-6: Setup for Alloy Test at Binding Posts	73
Figure 9-7: Setup for Alloy Test at Thermocouple Connector	74
Figure 9-8: Setup for Output-current Test	75
Figure B-1: Type E Thermocouple Calibration Setup	93

SECTION I

DESCRIPTION

GENERAL

The Model 1140A is a third-generation thermocouple simulator-calibrator from Ectron Corporation. It is capable of measuring and producing precise emf's to satisfy a wide variety of thermocouple and dc-voltage calibration needs. Direct entry of voltage and temperature allow the user to simulate twelve thermocouple types using copper and alloy material. In addition, measurements can be made of external voltages, which can be converted and displayed as temperature for various thermocouple types. Additionally, the Model 1140A can serve as a data logger with the capability to capture 10,000 data points, display them, and download the data in comma-separated value (.csv) format. Data downloading is accomplished through a remote interface such as USB.

The bench-mount instrument is 4" high (including feet) and contains the power and remote interface connectors on the rear panel along with the power fuse. The front panel contains a graphics LCD display with user-controllable brightness and contrast that, in addition to the emf being supplied or measured, shows the thermocouple type in use, the units of measure, the output material, and other annunciators. A front-panel **KEYPAD** and rotary **ENCODER** provide for data entry. Two sets of front-panel output terminals allow for connection of thermocouple connectors, banana plugs, wires, or clip leads.

Up to two optional remote interfaces may be installed as plug-ins to the digital board. The interfaces are isolated from the analog sections of the unit.

The temperature of each output terminal is independently measured, and compensation is independently applied to cancel the emf's generated at each of the terminals. This eliminates the need for thermally coupled terminals (such as those used in the Ectron Model 1120).

The user can set output zero to compensate for offsets in equipment or connections. This is limited to a $\pm 5^{\circ}\text{C}$ range, and an annunciator on the LCD display will be on while the offset is in effect. The offset can be disabled at any time from the front panel. The same feature is available for each thermocouple type, which eliminates offset problems when switching from one thermocouple type to another.

A diagnostic feature is provided such that the output of the unit is monitored to detect if the output is out of tolerance due to output overload. An annunciator on the display indicates if the output is out of tolerance, and an error message is sent via any installed interface.

The Model 1140A has the potential to simulate and measure twelve different thermocouple types. This allows the unit to simulate outputs of thermocouples to various international specifications. Selection of the desired thermocouple type is by front-panel menus.

A number of setups can be stored in nonvolatile memory. The entire set of operating conditions can be stored for up to 31 points. These stored setups can be given alphanumeric names to provide more user-friendly annotation for later recall.

A group of up to 31 setups can be arranged into a test sequence, and the Model 1140A can be commanded to step through the setups forward or backward. In this way frequently used tests

Description

may be easily repeated. The sequencing can even be done in a timed manner with the user establishing the time of each step. The sequence can also be repeated automatically.

CHANGES ACROSS DIFFERENT VERSIONS

Several changes have been introduced over the production history of the Model 1140A, as summarized below. These differences are also noted throughout this manual when the topics are presented in greater detail.

Most units with serial numbers below 81000 will have firmware versions 3.99 or below, but this is not always the case, e.g. if an older unit recently underwent significant repairs. Therefore some transition points are identified by serial number while others depend on the firmware version.

Battery

The rechargeable battery is available for units with serial numbers above 75700.

Remote Communications

For firmware below 3.99, USB drivers were supplied on the CD included with the unit. Contact Ectron if you need a copy of those files and the installation instructions.

For firmware above 4.00, USB is built into the unit and no longer counts as one of the two optional interfaces. Additionally, driver installation is no longer needed to connect from LabVIEW to a Model 1140A using the USB interface. The current Model 1140A is a USB Test & Measurement Class (USBTMC) device.

Additionally, the RS-232 remote interface became available at firmware above 4.00.

Standby Mode and Temperature Shortcuts

For firmware above 4.00, standby mode was introduced and several new functions were added to the front-panel controls of the Model 1140A. In standby, the output terminals are disconnected from the voltage source within the instrument. The **OPR/STBY (ENTER)** key toggles standby off or on. The up and down **ARROW KEYS** have the additional function of keying in either °C or °F without having to go into the menus. See [Front-panel Controls](#) for details.

Terminal Alignment Corrections

With firmware 4.40 and above, two additional options were added to the ALIGNMENT MENU, which allow the user to enter corrections to the results of the terminal alignment.

These options are also available in firmware 3.55.

ABOUT THIS MANUAL

[Section II](#) contains the complete set of specifications for the Model 1140A and [Section III](#) contains instructions for unpacking and installation of the instrument. [Section IV](#) is the operator's guide to use the instrument, [Section V](#) contains application information when using the Model 1140A, and [Section VI](#) addresses remote operation. The theory of operation is described in [Section VII](#). [Section VIII](#) details how to align the unit and [Section IX](#) is a complete

calibration procedure (accompanying test reports are provided in [Appendix A](#)). [Appendix B](#) provides a procedure to calibrate a thermocouple.

A separate Model 1140A Service Manual is available with troubleshooting and repair instructions as well as the parts list. Contact Ectron if you need a copy of the service manual.

In this manual, front-panel controls are indicated by bold, capitalized text (for example, **ENCODER**). Words that are displayed on the screen of the Model 1140A are indicated by non-bold, capitalized text (for example, SEQUENCE).

If you need assistance operating the Model 1140A or you have comments about or corrections for this manual or the Model 1140A, contact Ectron and ask for Technical Support. Ectron's contact information is at the beginning of this manual.

SECTION II

SPECIFICATIONS

GENERAL

Unless otherwise noted, these specifications apply at $23^{\circ}\text{C} \pm 3^{\circ}\text{C}$, after a 30 minute warm-up period, for one year without calibration. Percentages and ratios are with respect to the output voltage in Source Mode, or the input voltage in Meter Mode.

SOURCE MODE

(Applies to both voltage and thermocouple outputs)

Voltage Range	-11 V dc to +11 V dc.
Output Impedance	$<0.05 \Omega$ at dc.
Output Current	Will meet all specifications to 50 mA; current-limited to <100 mA.
Protection	Fused to withstand 120 V ac rms applied to the inputs.
Resolution	
Temperature	Selectable settings of 0.01° , 0.1° , and 1° (0.01, 0.1, and 1 if the unit of measure is kelvin).
Voltage	Selectable settings of $0.1 \mu\text{V}$, $1 \mu\text{V}$, $10 \mu\text{V}$, $100 \mu\text{V}$, and 1 mV . ($1 \mu\text{V}$ is the maximum setting at $\pm 1 \text{ V}$ and higher.)
Maximum Display	
Temperature	6 digits.
Voltage	7 digits.
Accuracy, 30 days	$\pm(20 \text{ ppm} + 1 \mu\text{V})$.
90 days	$\pm(22.5 \text{ ppm} + 1.5 \mu\text{V})$.
Six months	$\pm(25 \text{ ppm} + 2 \mu\text{V})$.
One year	$\pm(30 \text{ ppm} + 2.5 \mu\text{V})$.
Two years	$\pm(35 \text{ ppm} + 3 \mu\text{V})$.
Temperature Coefficient	$\pm(5 \text{ ppm}/^{\circ}\text{C} + 0.2 \mu\text{V}/^{\circ}\text{C})$.
Line Regulation	$\pm(5 \text{ ppm} + 2 \mu\text{V})$ for a +5% line-voltage change.
Noise	$<1 \mu\text{V}$ peak, 0.1 Hz to 10 Hz bandwidth.
Settling Time	
Thermocouple Ranges	<200 ms to rated accuracy.
Voltage Ranges	<1 s to rated accuracy.
Slew Rate	$>100 \text{ V/s}$.
Maximum Common-mode Voltage	100 V dc or peak ac.
Common-mode Rejection	160 dB at dc, 140 dB at 60 Hz.
Isolation	$<500 \text{ nA}$ peak-to-peak leakage current into the output from the power mains.

Thermocouple Output Mode

Accuracy	See Tables 2-1 through 2-24 .
Units	$^{\circ}\text{C}$, $^{\circ}\text{F}$, $^{\circ}\text{R}$, and K.

Conformity Error	<0.4 μ V.
Cold-junction Compensation Error	<0.004°C/°C.

Voltage Output Mode

Units	mV and V.
-------	-----------

METER MODE

Voltage Input	-11 V dc to +11 V dc.
Input Impedance	>10 M Ω nominal.
Pumpout Current	<1 nA.
Protection	Same as Source Mode.
Accuracy	Same as Source Mode.
Resolution	Same as Source Mode.
Temperature Coefficient	Same as Source Mode.
Settling Time	<10 s to rated accuracy.

SUPPORTED STANDARDS

Thermocouple Types	
B, E, J, K, R, S, and T	NIST <i>Monograph 175</i> and <i>Monograph 125</i> .
N	NIST <i>Monograph 175</i> and <i>Monograph 161</i> .
C and D	ASTM E230.
G and PLII	ASTM E1751.
Temperature Scales	ITS-90 and IPTS-68.

GENERAL INSTRUMENT SPECIFICATIONS

Ac Operation	
Line Voltage	85 V ac to 250 V ac, 47 Hz to 63 Hz.
Line Current	140 mA ac rms when battery pack is fully charged and less than 1 A when the battery pack is being recharged.
Dc Operation (for units with battery option installed) ¹	
Operation Time	More than six hours when the battery pack is fully charged.
Recharge Time	Less than three hours to fully recharge from a fully discharged state.

CAUTION

The battery pack used in the Model 1140A must be charged at least once every two months. If this is not done, the battery-pack voltage may decay beyond its ability to recover.

Display	LCD with adjustable contrast and backlight, which can be turned off, on, or timed out with settings of 30 seconds, one minute, two minutes, or five minutes.
---------	--

¹ The rechargeable battery is available for units with serial numbers above 75700.

Specifications

Remote Interfaces	USB included; Ethernet, GPIB, and RS-232 optional. ²
Other Available Options	Carrying case. Calibration kit consisting of a terminal cover, shorting bar, low-thermal cable, calibrated Type T thermocouple, and calibrated Type E thermocouple.
Temperature Ranges	
Operating	0°C to +50°C.
Storage, without battery	-20°C to +60°C.
Storage, with battery	0°C to +60°C.
Battery Recharge	+5°C to +45°C.
Dimensions	
Bench Mount	368 mm (14.50") wide. 381 mm (15.00") deep. 102 mm (4.00") high, including feet.
Rack Mount	482 mm (19.00") wide. 396 mm (15.60") deep. 89 mm (3.50") high, without feet.
Humidity	10% to 90% noncondensing.
Mass	4.5 kg (10 lb) without battery; 5.8 kg (13 lb) with battery.

THERMOCOUPLE-ACCURACY TABLES

The following tables are provided to easily ascertain the maximum error allowed for the thermocouple types supported. They apply when either sourcing or measuring temperature with thermocouple wires. A 95% confidence level ($k = 2$) is assumed. The errors were derived using the RSS (root of the sum of the squares) of all the applicable sources for error. These errors include:

1. Cold-junction compensation (if used without CJC, errors are reduced).
2. Variation of the environmental temperature by $\pm 5^\circ\text{C}$ from calibration temperature. If a better temperature environment is maintained, errors will be reduced.
3. Noise, 1 μV peak in a "0.1 Hz to 10 Hz" bandwidth.
4. Accuracy, as listed on page 4 for periods of 30 days, six months, and one year.
5. Uncertainty limits ($k = 2$) of Ectron's temperature measurement system, $\pm 0.01^\circ\text{C}$.
6. Conformity, $\pm 0.4 \mu\text{V}$.

² In units with firmware below 3.99, RS-232 was not available and USB was not built in.

Table 2-1: Type B Thermocouple (°C)

Temperature Range		Error After:		
		30 Days	Six Months	One Year
250	<350	±0.58	±0.85	±0.95
350	<445	±0.41	±0.60	±0.74
445	<580	±0.33	±0.49	±0.58
580	<750	±0.26	±0.38	±0.45
750	<1000	±0.21	±0.31	±0.37
1000	1820	±0.17	±0.24	±0.29

Table 2-2: Type B Thermocouple (°F)

Temperature Range		Error After:		
		30 Days	Six Months	One Year
482	<662	±1.04	±1.53	±1.71
662	<833	±0.74	±1.08	±1.33
833	<1076	±0.59	±0.88	±1.04
1076	<1382	±0.47	±0.68	±0.81
1382	<1832	±0.38	±0.56	±0.67
1832	3308	±0.31	±0.43	±0.52

Table 2-3: Type C Thermocouple (°C)

Temperature Range		Error After:		
		30 Days	Six Months	One Year
0	<250	±0.12	±0.16	±0.20
250	<1000	±0.10	±0.13	±0.16
1000	<1500	±0.11	±0.15	±0.18
1500	<1800	±0.13	±0.18	±0.21
1800	<2000	±0.14	±0.20	±0.23
2000	<2250	±0.17	±0.24	±0.29
2250	2315.56	±0.19	±0.26	±0.32

Table 2-4: Type C Thermocouple (°F)

Temperature Range		Error After:		
		30 Days	Six Months	One Year
32	<482	±0.22	±0.29	±0.36
482	<1832	±0.18	±0.23	±0.29
1832	<2732	±0.20	±0.27	±0.32
2732	<3272	±0.23	±0.32	±0.38
3272	<3632	±0.25	±0.36	±0.41
3632	<4082	±0.31	±0.43	±0.52
4082	4200.01	±0.34	±0.47	±0.58

Table 2-5: Type D Thermocouple (°C)

Temperature Range		Error After:		
		30 Days	Six Months	One Year
0	<100	±0.16	±0.23	±0.27
100	<300	±0.12	±0.17	±0.20
300	<1400	±0.10	±0.13	±0.15
1400	<1650	±0.10	±0.15	±0.17
1650	<1930	±0.12	±0.16	±0.20
1930	<2100	±0.14	±0.19	±0.23
2100	<2200	±0.15	±0.21	±0.25
2200	2320	±0.18	±0.25	±0.30

Table 2-6: Type D Thermocouple (°F)

Temperature Range		Error After:		
		30 Days	Six Months	One Year
32	<212	±0.29	±0.41	±0.49
212	<572	±0.22	±0.31	±0.36
572	<2552	±0.18	±0.23	±0.27
2552	<3002	±0.18	±0.27	±0.31
3002	<3506	±0.22	±0.29	±0.36
3506	<3812	±0.25	±0.34	±0.41
3812	<3992	±0.27	±0.38	±0.45
3992	4208	±0.32	±0.45	±0.54

Table 2-7: Type E Thermocouple (°C)

Temperature Range		Error After:		
		30 Days	Six Months	One Year
-270	<-245	±0.95	±1.10	±1.20
-245	<-195	±0.13	±0.16	±0.18
-195	<-155	±0.07	±0.09	±0.10
-155	<-90	±0.06	±0.07	±0.08
-90	<15	±0.05	±0.06	±0.07
15	<890	±0.05	±0.06	±0.06
890	1000	±0.05	±0.06	±0.07

Table 2-8: Type E Thermocouple (°F)

Temperature Range		Error After:		
		30 Days	Six Months	One Year
-454	<-409	±1.71	±1.98	±2.16
-409	<-319	±0.23	±0.29	±0.32
-319	<-247	±0.13	±0.16	±0.18
-247	<-130	±0.11	±0.13	±0.14
-130	<59	±0.09	±0.11	±0.13
59	<1634	±0.09	±0.11	±0.11
1634	1832	±0.09	±0.11	±0.13

Table 2-9: Type G Thermocouple (°C)

Temperature Range		Error After:		
		30 Days	Six Months	One Year
0	<100	±1.10	±1.30	±1.50
100	<300	±0.28	±0.35	±0.43
300	<600	±0.14	±0.19	±0.24
600	<1760	±0.10	±0.13	±0.15
1760	<2030	±0.11	±0.15	±0.18
2030	<2200	±0.13	±0.17	±0.21
2200	2315.56	±0.14	±0.20	±0.24

Table 2-10: Type G Thermocouple (°F)

Temperature Range		Error After:		
		30 Days	Six Months	One Year
32	<212	±1.98	±2.34	±2.70
212	<572	±0.50	±0.63	±0.77
572	<1112	±0.25	±0.34	±0.43
1112	<3200	±0.18	±0.23	±0.27
3200	<3686	±0.20	±0.27	±0.32
3686	<3992	±0.23	±0.31	±0.38
3992	4200.01	±0.25	±0.36	±0.43

Table 2-11: Type J Thermocouple (°C)

Temperature Range		Error After:		
		30 Days	Six Months	One Year
-210	<-180	±0.07	±0.10	±0.12
-180	<-120	±0.06	±0.09	±0.10
-120	<-50	±0.06	±0.07	±0.08
-50	<990	±0.05	±0.06	±0.07
990	1200	±0.05	±0.07	±0.07

Table 2-12: Type J Thermocouple (°F)

Temperature Range		Error After:		
		30 Days	Six Months	One Year
-346	<-292	±0.13	±0.18	±0.22
-292	<-184	±0.11	±0.16	±0.18
-184	<-58	±0.11	±0.13	±0.14
-58	<1814	±0.09	±0.11	±0.13
1814	2192	±0.09	±0.13	±0.13

Table 2-13: Type K Thermocouple (°C)

Temperature Range		Error After:		
		30 Days	Six Months	One Year
-270	<-255	±1.50	±1.90	±2.20
-255	<-195	±0.30	±0.40	±0.70
-195	<-115	±0.10	±0.11	±0.12
-115	<-55	±0.07	±0.08	±0.09
-55	<1000	±0.06	±0.07	±0.07
1000	1372	±0.06	±0.08	±0.08

Table 2-14: Type K Thermocouple (°F)

Temperature Range		Error After:		
		30 Days	Six Months	One Year
-454	<-427	±2.70	±3.42	±3.96
-427	<-319	±0.54	±0.72	±1.26
-319	<-175	±0.18	±0.20	±0.22
-175	<-67	±0.13	±0.14	±0.16
-67	<1832	±0.11	±0.13	±0.13
1832	2501.6	±0.11	±0.14	±0.14

Table 2-15: Type N Thermocouple (°C)

Temperature Range		Error After:		
		30 Days	Six Months	One Year
-270	<-260	±3.50	±4.00	±5.00
-260	<-200	±0.75	±0.93	±1.00
-200	<-140	±0.15	±0.19	±0.23
-140	<-70	±0.10	±0.12	±0.15
-70	<25	±0.08	±0.10	±0.12
25	<160	±0.07	±0.09	±0.10
160	1300	±0.07	±0.08	±0.09

Table 2-16: Type N Thermocouple (°F)

Temperature Range		Error After:		
		30 Days	Six Months	One Year
-454	<-436	±6.30	±7.20	±9.00
-436	<-328	±1.35	±1.67	±1.80
-328	<-220	±0.27	±0.34	±0.41
-220	<-94	±0.18	±0.22	±0.27
-94	<77	±0.14	±0.18	±0.22
77	<320	±0.13	±0.16	±0.18
320	2372	±0.13	±0.14	±0.16

Table 2-17: Type Platinel II Thermocouple (°C)

Temperature Range		Error After:		
		30 Days	Six Months	One Year
0	<100	±0.07	±0.08	±0.10
100	<925	±0.06	±0.07	±0.08
925	<1200	±0.07	±0.08	±0.10
1200	1395	±0.08	±0.09	±0.11

Table 2-18: Type Platinel II Thermocouple (°F)

Temperature Range		Error After:		
		30 Days	Six Months	One Year
32	<212	±0.13	±0.14	±0.18
212	<1697	±0.11	±0.13	±0.14
1697	<2192	±0.13	±0.14	±0.18
2192	2543	±0.14	±0.16	±0.20

Table 2-19: Type R Thermocouple (°C)

Temperature Range		Error After:		
		30 Days	Six Months	One Year
-50	<-30	±0.40	±0.58	±0.65
-30	<45	±0.34	±0.48	±0.55
45	<160	±0.24	±0.32	±0.40
160	<380	±0.18	±0.26	±0.30
380	<775	±0.15	±0.21	±0.26
775	1768.1	±0.13	±0.18	±0.22

Table 2-20: Type R Thermocouple (°F)

Temperature Range		Error After:		
		30 Days	Six Months	One Year
-58	<-22	±0.72	±1.04	±1.17
-22	<113	±0.61	±0.86	±0.99
113	<320	±0.43	±0.58	±0.72
320	<716	±0.32	±0.47	±0.54
716	<1427	±0.27	±0.38	±0.47
1427	3214.58	±0.23	±0.32	±0.40

Table 2-21: Type S Thermocouple (°C)

Temperature Range		Error After:		
		30 Days	Six Months	One Year
-50	<-30	±0.38	±0.53	±0.62
-30	<45	±0.32	±0.47	±0.56
45	<105	±0.23	±0.34	±0.40
105	<310	±0.20	±0.30	±0.33
310	<615	±0.17	±0.25	±0.29
615	1768.1	±0.15	±0.22	±0.26

Table 2-22: Type S Thermocouple (°F)

Temperature Range		Error After:		
		30 Days	Six Months	One Year
-58	<-22	±0.68	±0.95	±1.12
-22	<113	±0.58	±0.85	±1.01
113	<221	±0.41	±0.61	±0.72
221	<590	±0.36	±0.54	±0.59
590	<1139	±0.31	±0.45	±0.52
1139	3214.58	±0.27	±0.40	±0.47

Table 2-23: Type T Thermocouple (°C)

Temperature Range		Error After:		
		30 Days	Six Months	One Year
-270	<-255	±1.40	±1.60	±1.80
-255	<-240	±0.27	±0.35	±0.49
-240	<-210	±0.17	±0.24	±0.30
-210	<-150	±0.11	±0.15	±0.18
-150	<-40	±0.08	±0.10	±0.12
-40	<100	±0.06	±0.07	±0.08
100	400	±0.05	±0.06	±0.07

Table 2-24: Type T Thermocouple (°F)

Temperature Range		Error After:		
		30 Days	Six Months	One Year
-454	<-427	±2.52	±2.88	±3.24
-427	<-400	±0.49	±0.63	±0.88
-400	<-346	±0.32	±0.43	±0.54
-346	<-238	±0.20	±0.27	±0.31
-238	<-40	±0.14	±0.18	±0.20
-40	<212	±0.11	±0.13	±0.14
212	752	±0.09	±0.11	±0.13

SECTION III

UNPACKING AND INSTALLATION

SHIPMENT CONTENTS

The Model 1140A is shipped from the factory with a power cord, a CD that contains the instruction manual, a calibration report, a certificate of conformance, and the attendant packing slip. Optional components such as a remote interface or battery will be installed in the unit.

UNPACKING

The Model 1140A was thoroughly test and inspected prior to shipment from the factory; unless it was damaged in transit, it should be ready for use upon receipt.

The shipping carton should be examined for signs of damage before unpacking. If external damage is seen, notify the carrier before proceeding.

Remove the contents of the carton and carefully examine all contents for any evidence of damage due to excessive shock, vibration, water, etc. If there is evidence of physical damage, notify the carrier.

Account for the items listed above and ensure that the serial number of the Model 1140A in the carton is that which is listed on the packing slip. If the inventory is not complete or does not correspond to the packing list, notify Ectron Corporation.

MODEL 1140A INSTALLATION

The battery (if any) in the Model 1140A is fully charged when shipped, but due to transit time or other delays it may have lost some charge by the time of first use. To ensure a full battery charge, plug the unit into ac power for three hours prior to running it on battery power.

While the Model 1140A is fully calibrated using standards that are directly traceable to the National Institute of Standards and Technology (NIST), the user may want to verify its performance against independent standards using the calibration procedure in this manual before placing it in service.

DRIVER INSTALLATION

In newly manufactured units, no drivers are necessary to connect to a computer. Refer to [Remote Operation](#) for details on remote communications.

For older units with firmware below 3.99, a driver and installation instructions were included on the CD that shipped with the unit. That driver should be installed if one of these older units will be connected to a computer using a USB interface. Contact Ectron if you need those files.

PACKING FOR SHIPMENT

Ectron Corporation ships each Model 1140A wrapped in a 4-mil static-protective plastic wrapper in a single-wall corrugated cardboard carton with foam-in-place protection. The carton measures

Unpacking and Installation

18 inches by 18 inches by 8 inches. When preparing the unit for shipment, either reuse the container in which it came or reproduce a similar shipping container with a like amount of foam (either closed-cell or open-cell) protection.

SECTION IV OPERATION

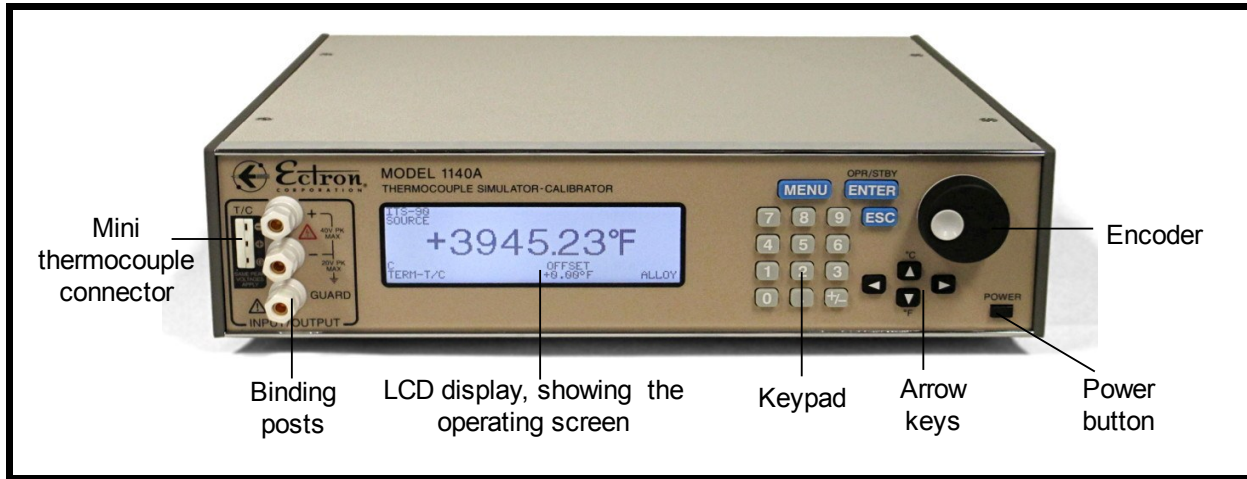

Figure 4-1: Front View of the Model 1140A

GENERAL

The microprocessor-based Model 1140A thermocouple simulator-calibrator can either be controlled from the front panel (local control) or controlled over one of several interfaces (remote control) offered by Ectron. Remote control is discussed in [Section VI](#).

In this manual, front-panel controls are indicated by bold, capitalized text (for example, **ENCODER**). Words that are displayed on the screen are indicated by non-bold, capitalized text (for example, SEQUENCE). When selection of a screen display is discussed, it is assumed that the selection includes pressing the **ENTER** key to confirm the selection.

FRONT-PANEL CONTROLS

The Model 1140A can be controlled from the front panel using the **ENCODER** and keys, which include the **NUMBER PAD**, the **MENU** key, the **ENTER** key, the **ESC**ape key, and the four **ARROW KEYS**.

The front-panel controls provide the user complete control of all setup parameters needed to operate the Model 1140A. Binding posts and a mini-three-pin thermocouple connector are provided for connections. Setup is accomplished through the Main Menu and its sub-menus.

Power

The **POWER** push button turns instrument power on and off. When the Model 1140A is running, power may be turned off at any time; no special shutdown procedures are needed.

Operation

By default if the Model 1140A is in source mode and the Model 1120 Remote Emulation option is not enabled, when power is turned on the unit will be in standby mode³ as indicated by the blinking annunciator in the lower right corner of the display. In standby, the output terminals are disconnected from the voltage source within the instrument. The **OPR/STBY (ENTER)** key toggles standby off or on. No other action by the operator will affect the standby condition.

Ac Operation

When the Model 1140A is plugged into an ac power source in the range as stated in [Section II](#), under [Ac Operation](#), the unit is operating in the ac-power mode, and the battery pack (if installed) will charge as necessary.

Dc Operation (Battery Option Only)⁴

When the battery pack has been properly charged the Model 1140A will operate (without being plugged into an ac power source) by simply pressing the **POWER** push button. When the battery pack is fully charged, the Model 1140A will operate for more than six hours without recharge.

Recharge

When the Model 1140A battery pack is fully discharged, it will recharge in less than three hours.

CAUTION

The battery pack used in the Model 1140A must be charged at least once every two months. If this is not done, the user risks the possibility that the battery-pack voltage will decay beyond its ability to recover.

Menu Key

Pushing the **MENU** key takes the user to the MAIN MENU from which all settings can be viewed and changed. Additionally, **MENU** can be used as a total-escape key from any menu or screen back to the operating screen of the main display.

Enter Key (Operate/Standby)³

The **ENTER** key allows the user to change settings. Additionally, in source mode at the operating screen this button toggles standby mode on and off.

Escape Key

Pressing the **ESC** key allows the user to go back to the previous screen or setting without having made a change.

³ Standby mode is available with firmware 4.00 and above.

⁴ The rechargeable battery is available for units with serial numbers above 75700.

Twelve-key Keypad

The **KEYPAD** is used for direct entry of numbers both on the operating screen and in the menu options that require a numeric value to be entered. Numbers to be entered can always be entered directly or can be arrived at using the **ARROW KEYS** and the **ENTER** key or the **ENCODER** in its dual function. Pressing the polarity key at any time toggles the polarity of the reading. Also, the +/- polarity key acts as a character-delete key when naming files in the MEMORY MENU.

Four Arrow Keys

The **ARROW KEYS** are used for navigation when in a menu and for cursor control and numeric incrementing and decrementing when in the main operating screen. Changes made using the **ARROW KEYS** are made in real time.

The left **ARROW KEY** has the additional function (not in real time) of erasing data input that has been keyed in but not confirmed (by pressing the **ENTER** key or the **ENCODER**). For example if the user enters 1.3456, pressing the left **ARROW KEY** will erase the digits one at a time starting with 6, then 5, etc. This includes the decimal point but not the polarity symbol.

When entering alphanumeric characters such as file names in the MEMORY MENU, the right **ARROW KEY** allows the user to append characters to the name. For example, when naming a file, "A" is the starting default. The user can then change that character and then by pressing the right **ARROW KEY**, append another character to the file name.

At the main operating screen the up and down **ARROW KEYS** have the additional function, when using the keypad for direct entry in source mode, to allow the user to key in either °C or °F without having to go into the menus. The only requirement is that the unit be in temperature mode (MAIN MENU / INSTRUMENT MODE / OUTPUT MODE). When entering temperatures in this manner, the °C and °F keys act as the **ENTER** key. For example, when the user keystrokes 125°C, the action is complete, and the unit will output the equivalent voltage. If the user then keystrokes 200°F, the action is again complete, and the the unit will output the equivalent voltage. When the °C or °F key is used, the system unit of temperature is changed as well. That is, if the user keys in 125°C and then wishes to key in 200°C, it can be accomplished either by using the °C key or by keying 125 and pressing **ENTER**.

If the user uses either the **ARROW KEYS** or the **ENCODER** to adjust the output temperature, the °C and °F functions of the up and down **ARROW KEYS** are disabled so that these two keys function only as **ARROW KEYS**. Once **ENTER** has been pressed, the °C and °F functions are re-enabled.

Encoder (Large Knob)

The **ENCODER** duplicates the action of the **ARROW KEYS** (by turning it) and the **ENTER** key (by pressing it). Changes made using the **ENCODER** are made in real time. Also, when creating a file name in the MEMORY MENU, pressing the **ENCODER** appends a character to the file name.

OPERATING SCREEN MAIN DISPLAY

About 15–20 seconds after powering on the Model 1140A, the operating screen will appear, displaying the current status and main settings of the unit.

Operation

Control

In Source Mode, the number displayed on the operating screen can be changed using the **KEYPAD**, the **ARROW KEYS**, and the **ENCODER**. When using the **ARROW KEYS** or the **ENCODER**, the change at the binding posts or thermocouple connector is in real time. When using the **KEYPAD**, **ENTER** (or °C or °F as described above) must be pressed to change the reading. To abort any entry, press **ESC** at which time the Model 1140A will revert to the last saved entry.

Mode

The Model 1140A operates in two modes: source and measure. In the source mode, the Model 1140A produces a voltage output; in the measure mode, it accepts a voltage input. The voltage is either in volts, millivolts, or in temperature (the emf equivalent for the type thermocouple that is active).

The active mode is displayed in the upper left corner of the main display.

Offset

The offset is used to compensate for any inaccuracies attributable to the instrumentation being used. For example if the thermocouple wire being used has been found to have +0.035°C error, that offset in the opposite polarity should be entered so that in the source mode, the meter being calibrated will read correctly, and in the meter mode, the Model 1140A will correctly display the temperature or voltage of the thermocouple being measured. Each thermocouple type has its own offset.

The offset is displayed in the lower middle right of the main display.

Reference-junction Temperature

The reference-junction temperature is the temperature at which the Model 1140A simulates the copper-to-thermocouple-wire (alloy) connections when using thermocouple wire. The connection is most often at the Model 1140A binding posts or thermocouple connector. The Model 1140A constantly measures the actual temperature of the terminals to provide precision compensation. Unless the user's setup has the copper-to-thermocouple-wire junctions remote to the Model 1140A, the reference-junction temperature should be set to 0°C. The allowable reference-junction temperatures is the temperature range for the thermocouple type being used and can be displayed in °C, °F, °R, K, or system units. The system units are whatever is set in the INSTRUMENT MODE MENU. Note that the reference-junction temperature is only used when the output-entry mode and the material differ in nature (temperature and copper connections or voltage and alloy connections).

The reference-junction temperature is displayed in the lower middle left of the main display.

Material

Either copper wires or alloy (thermocouple) wires can be connected to the Model 1140A. The user should set the MATERIAL to match the wiring being used.

The material is displayed in the lower right of the main display.

Table 4-1: Thermocouple Types in the Model 1140A

Type*	Positive Wire	Negative Wire	Temperature Range
B-MN175 [B-MN125]	70% Pt – 30% Rh Alloy	94% Pt – 6% Rh Alloy	250°C to 1820°C 482°F to 3308°F 523.15 K to 2093.15 K 22.33°R to 3767.67°R
C	95% W – 5% Re Alloy	74% W – 26% Re Alloy	0°C to 2315.56°C 32°F to 4200.01°F 273.15 K to 2588.71 K 491.67°R to 4659.68°R
D	97% W – 3% Re Alloy	75% W – 25% Re Alloy	0°C to 2320°C 32°F to 4208°F 273.15 K to 2593.15 K 491.67°R to 4667.67°R
E-MN175 [E-MN125]	90% Ni – 10% Cr Alloy (Chromel)	55% Cu – 45% Ni Alloy (Constantan)	–270°C to 1000°C –454°F to 1832°F 3.15 K to 1273.15 K 5.67°R to 2291.67°R
G	100% W	74% W – 26% Re Alloy	0°C to 2315.56°C 32°F to 4200.01°F 273.15 K to 2588.71 K 491.67°R to 4659.68°R
J-MN175 [J-MN125]	100% Fe	55% Cu – 45% Ni Alloy (Constantan)	–210°C to 1200°C –346°F to 2192°F 63.15 K to 1473.15 K 113.67°R to 2651.67°R
K-MN175 [K-MN125]	90% Ni – 10% Cr Alloy (Chromel)	96% Ni – 2% Mn – 2% Al Alloy (Alumel)	–270°C to 1372°C –454°F to 2501.6°F 3.15 K to 1645.15 K 5.67°R to 2961.27°R
N-MN175 [N-MN161]	84% Ni – 14% to 14.4% Cr – 1.3% to 1.6% Si Alloy	95% Ni – 4.2% to 4.6% Cr – 0.5% to 1.5% Mg Alloy	–270°C to 1300°C –454°F to 2372°F 3.15 K to 1573.15 K 5.67°R to 2831.67°R
PLII (Platinel II™)	Proprietary Platinum Alloy	Proprietary Platinum Alloy	0°C to 1395°C 32°F to 2543°F 273.15 K to 1668.15 K 459.67°R to 3002.67°R
R-MN175 [R-MN125]	87% Pt – 13% Rh Alloy	100% Pt	–50°C to 1768.1°C [1767.6°C]** –58°F to 3214.58°F [3213.68°F] 223.15 K to 2041.25 K [2040.75K] 401.67°R to 3674.25°R [3673.35°R]
S-MN175 [S-MN125]	90% Pt – 10% Rh Alloy	100% Pt	–50°C to 1768.1°C [1767.6°C]** –58°F to 3214.58°F [3213.68°F] 223.15 K to 2041.25 K [2040.75K] 401.67°R to 3674.25°R [3673.35°R]
T-MN175 [T-MN125]	100% Cu	55% Cu – 45% Ni Alloy (Constantan)	–270°C to 400°C –454°F to 752°F 3.15 K to 673.15 K 5.67°R to 1211.67°R
<p>* MN175 is NIST <i>Monograph 175</i>, which is based on ITS-90. In units with firmware above 4.00, when using IPTS-68 the thermocouple types are those shown in [brackets], referencing NIST <i>Monograph 125</i> and <i>Monograph 161</i>.</p> <p>** The upper temperature limits for Types R and S are slightly lower in NIST <i>Monograph 125</i> than in NIST <i>Monograph 175</i>.</p>			

Operation

Thermocouple Type

Table 4-1 lists the thermocouple types available in the Model 1140A. The active thermocouple type is displayed in the lower left corner of the main display.

Message Displays

Standby⁵

By default if the Model 1140A is in source mode, when power is turned on the unit will be in standby mode as indicated by the blinking annunciator in the lower right corner of the display. In standby, the output terminals are disconnected from the voltage source within the instrument. The **OPR/STBY (ENTER)** key toggles standby off or on. No other action by the operator will affect the standby condition.

Overload

If the Model 1140A is incapable of supplying the output that is displayed, the word OVERLOAD will appear in the lower right portion of the main display over the material, either ALLOY or COPPER. With an overload on either output (binding posts or thermocouple connector), no matter which one is in use, the OVERLOAD annunciator will light. A sustained overload will not affect the operation of the Model 1140A once the overload is removed.

Out of Range

If the temperature dialed or keyed in is outside the range of the thermocouple type displayed on the main display, an annunciator will light to convey that fact. If the user attempts to enter a voltage that is outside the range of the Model 1140A, no error message will appear, but the instrument will not accept the input.

Alignment Switch On

If the alignment switch is in the on position when the Model 1140A power switch is pressed, the following message will appear:

ALIGNMENT SWITCH IS ON
ALL ALIGNMENT FUNCTIONS ENABLED
PRESS ANY KEY TO CONTINUE

The switch's being "on" does not affect the operation of the unit, and it can be switched "off" while the instrument power is on. Normally a calibration-void label would cover the access to the switch, so the every-day user of the instrument will not see this message. For details on the alignment switch and procedure, see [Section VIII](#).

Battery-related Messages

The following messages will only appear on units that have the optional rechargeable battery.

Charging

This indicator is displayed whenever the battery is charging.

⁵ Standby mode is available with firmware 4.00 and above.

Charged

This indicator is displayed when the battery is fully charged. The user can unplug from ac power at this time although there will be no harm to the battery if left plugged in. In fact, if left plugged in charging will continue at a reduced charging current which will further increase the charge level of the battery. When this trickle charge rate has finished “topping off” the battery, the charge circuit will cease all charging.

Low Batt

This is a blinking message which indicates that the remaining life of the battery is approximately 30 minutes from the time that the message first appears. Thirty minutes after the warning appears, the instrument will cease to function on the battery and must be connected to the ac line for operation and to recharge the battery pack.

Batt Flt

This display indicates a battery fault and that the battery probably cannot be recharged. This fault can be caused by a shorted cell in the battery pack. Normal operation can continue on ac power. See the separate Model 1140A Service Manual to change the battery.

Temp Flt

The temperature of the internal battery pack is continuously monitored to allow for optimum performance and life of the battery. Because of the charging limits imposed by the manufacturer of the battery pack, the battery must not be charged when its temperature is outside of certain temperature limits. These limits are between 5°C and 45°C. However, the upper limit in temperature is increased to 60°C once charging has commenced.

To rectify this situation, place the instrument in an area where the temperature is within acceptable temperature limits. If necessary, turn off the unit and unplug it from ac power to allow the internal temperature to cool down sufficiently, then plug it in to reattempt charging.

Other Messages

There are other diagnostic messages that will appear very infrequently if ever. Refer to the separate Service Manual or contact Ectron and ask for Technical Support should one of the following appear. Ectron’s contact information is at the beginning of this manual.

System Errors

System errors may occur at startup or anytime there is a component failure. If one occurs, the Model 1140A must be repaired. These errors include: AT25640 EEPROM ERROR, NVDATA CHECKSUM ERROR, A/D ERRORS, OPTION BOARD ERRORS, A/D IS ALWAYS READY, SELF-ALIGNMENT TIMEOUT, INVALID PRE-ALIGN MODE, and INVALID POST-ALIGN MODE.

Alignment Failure

During alignment, errors may occur such as DAC BIT ALIGNMENT FAILED or TERMINAL ALIGNMENT FAILED. In any such case, the alignment will be aborted and the unit will retain the previous alignment data. To complete an alignment, the Model 1140A must be repaired.

Operation

Interface Board Errors

These errors are associated with the remote-interface boards that can be installed in the Model 1140A: UNKNOWN OPTION BOARD IN SLOT #1, UNKNOWN OPTION BOARD IN SLOT #2, CAN'T FIND [INTERFACE] OPTION BOARD, and [INTERFACE] OPTION BOARD FAILED. These errors can occur if, for example, the unit's power is turned off with a GPIB board installed, the user removes the board, and power is then applied. In this instance, the error would be: CAN'T FIND GPIB OPTION BOARD.

MENUS

From the operating screen, pressing **MENU** will take the user to the MAIN MENU. If the cursor is active, pressing **MENU** has no effect. Figure 4-2 shows the MAIN MENU. Once at the MAIN MENU or any other menu, use the **ENCODER** or the **ARROW KEYS** to navigate. Once the desired menu item is highlighted (selected), press **ENTER** to go to that menu.

NOTE

When a segmented vertical bar appears to the right of a menu, more selections than can be displayed are available. A segment of the bar that points up denotes additional menu selections above, and a segment of the bar that points down denotes additional menu selections below. The MAIN MENU is such a menu.

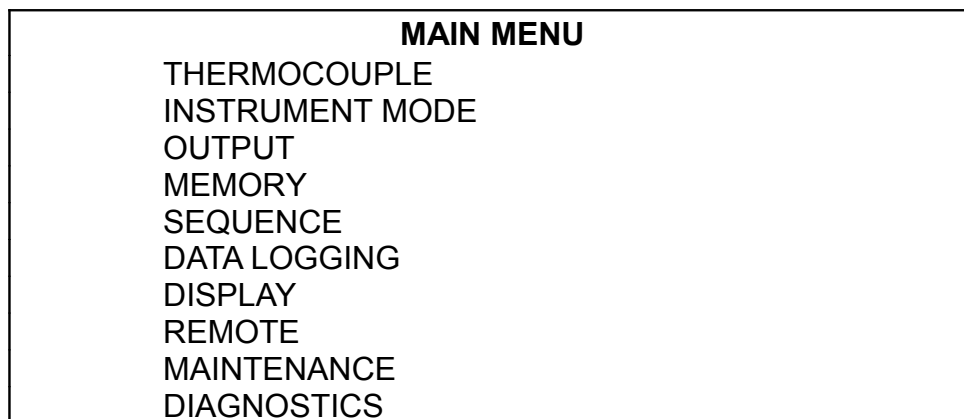

Figure 4-2: Main Menu

<p>THERMOCOUPLE MENU THERMOCOUPLE TYPE: K-MN175 THERMOCOUPLE OFFSET UNITS: SYSTEM UNITS THERMOCOUPLE OFFSET: +0.00°C REF JCT TEMP UNITS: SYSTEM UNITS REF JCT TEMP: +0.00°C</p>

Figure 4-3: Thermocouple Menu

Thermocouple Menu

Figure 4-3 shows the THERMOCOUPLE MENU.

Thermocouple Type

Select a THERMOCOUPLE TYPE from those listed in Table 4-1.

Thermocouple Offset

When using alloy wire, if there are known inaccuracies in the instrumentation being used (for example, in the thermocouple wire), the offset will compensate for that error.

Thermocouple Offset Units

Select CELSIUS (°C), FAHRENHEIT (°F), RANKINE (°R), KELVIN (K), or SYSTEM UNITS, which are those units set under the INSTRUMENT MODE MENU.

Thermocouple Offset

It is advisable to select the thermocouple-offset units before entering this value because the Model 1140A converts the temperature offset to match the units. For example, if the user sets the OFFSET to 1.0 when the UNITS are set to CELSIUS and then changes the units to FAHRENHEIT, the thermocouple offset displayed will convert automatically from 1.0°C to +1.8°F, which of course is the equivalent offset. The limits are -5°C to +5°C (-9°F to +9°F, -5 K to +5 K, and -9°R to +9°R). Each thermocouple type has its own offset.

Reference-junction Temperature

Although in most instances a reference-junction temperature of 0°C is desired, the operator can enter any reference-junction temperature with the temperature range of the thermocouple module in use.

Reference-junction-temperature Units

Select CELSIUS (°C), FAHRENHEIT (°F), RANKINE (°R), KELVIN (K), or SYSTEM UNITS, which are those units set under the INSTRUMENT MODE MENU.

Reference-junction Temperature

Select any valid temperature within the range of the thermocouple type to be used. See Table 4-1. Note that when the reference-junction-temperature units are changed, the setting of the reference-junction temperature will change accordingly. For example, if the user selects 0.0 as the reference-junction temperature when the units are set to CELSIUS and then changes the units

Operation

to FAHRENHEIT, the reference-junction temperature will convert automatically from 0.0°C to +32.0°F, which of course is the equivalent.

```

INSTRUMENT MODE MENU
INSTRUMENT MODE: SOURCE
OUTPUT MODE: TEMPERATURE
SYSTEM TEMPERATURE UNITS: CELSIUS
SYSTEM VOLTAGE UNITS: MILLIVOLTS
TEMPERATURE RESOLUTION LIMIT: 0.01°
VOLTAGE RESOLUTION LIMIT: 0.1 µV
TEMPERATURE SCALE: ITS-90

```

Figure 4-4: Instrument Mode Menu

Instrument Mode Menu

Instrument Mode

Select SOURCE for the Model 1140A to act as a source; that is, to provide a simulated temperature out or provide a linear voltage output. Select METER for the Model 1140A to act as a meter to measure either linear voltage or the voltage input of a thermocouple.

Output Mode

Select TEMPERATURE or VOLTAGE.

System Temperature Units

When working with thermocouples, select the units of temperature to use: CELSIUS, FAHRENHEIT, RANKINE, or KELVIN.

System Voltage Units

When working with linear dc voltage, select the appropriate voltage units: VOLTS or MILLIVOLTS.

NOTE

Although the MILLIVOLTS unit of measure provides more resolution for the user than VOLTS, there is no difference in accuracy between settings that are equal in value. For example 0.01 V is the same internally as 10.0 mV, and 10.0 V is the same as 10000.00 mV.

Temperature Resolution Limit

Select the desired resolution that will be displayed on the main operating screen: 0.01°, 0.1°, or 1° (0.01, 0.1, or 1 when the system temperature unit is kelvin). When the operating screen is being changed with the **ENCODER** or **ARROW KEYS**, the maximum resolution is displayed; but when **ENTER** is pressed, the selected resolution is displayed.

Voltage Resolution Limit

Select the desired resolution that will be displayed on the main operating screen: 0.1 μV , 1 μV , 10 μV , 100 μV , or 1 mV. When the operating screen is being changed, the maximum resolution is displayed; but when the **ENTER** key is pressed, the selected resolution is displayed. Because of some internal constraints, the resolution may be reduced. For example, if the MODE is set to METER, the OUTPUT MODE is set to VOLTAGE, and UNIT OF MEASURE is set to VOLTS; the maximum resolution will be 10 μV .

Temperature Scale

Select the temperature scale to be used: the International Scale of 1990 (ITS-90) or the International Practical Temperature Scale of 1968, amended edition of 1975 (IPTS-68). Although the ITS-90 supersedes the IPTS-68, Ectron offers both scales.

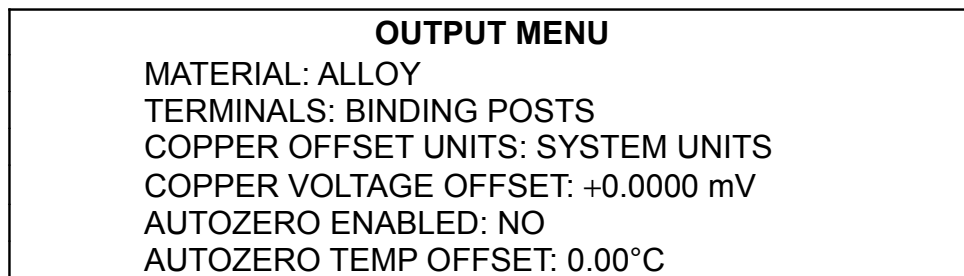

Figure 4-5: Output Menu

Output Menu

The OUTPUT MENU allows the user to select the wire material, which terminals are active, the copper offset units, the copper voltage offset, whether autozero is enabled, and the autozero temperature offset.

Wire Material

If the wire connections to the Model 1140A are copper, select COPPER; if thermocouple wire, ALLOY.

Terminals

Select binding posts or T/C connector depending on the terminals being used. Either copper or alloy wire can be connected to either input. However, when using alloy, the selected terminals are the only terminals at which the temperature is being monitored for compensation.

NOTE

Using the terminal other than the one selected will cause erroneous readings when working with thermocouple wires.

Operation

Copper Voltage Offset

When using copper material, this offset is used to compensate for any inaccuracies attributable to the instrumentation being used. For example if an instrument being used has a known offset at 0 V, that offset in the opposite polarity should be entered so that in source mode the Model 1140A will output an adjusted voltage, or in meter mode the Model 1140A will correctly display the input voltage.

Copper Offset Units

Select VOLTS, MILLIVOLTS, or SYSTEM UNITS, which are those units set under the INSTRUMENT MODE MENU.

Copper Voltage Offset

Select any voltage from -11000 mV to +11000 mV.

Autozero Enabled

Autozero is used in the meter mode to allow the user to measure the deviation that an input has from its nominal value. For example, if a thermocouple at a known temperature is being measured, enabling autozero will “zero” the reading on the screen so that any subsequent readings will reflect a deviation, if any, from the initial reading. When using the meter mode, pressing the **0** key evokes the AUTOZERO screen from which the user can enable autozero.

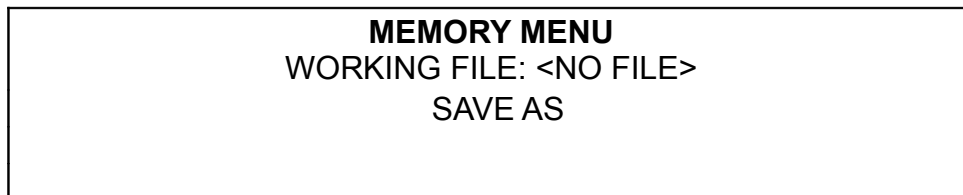

Figure 4-6: Memory Menu with No Saved Files

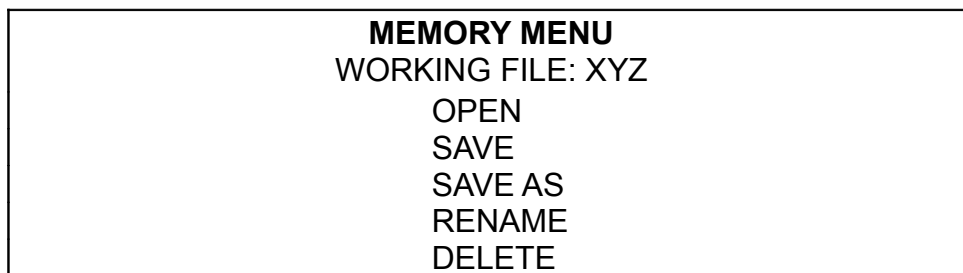

Figure 4-7: Memory Menu with Saved Files

Memory Menu

The MEMORY MENU allows the user to program up to 31 files into memory for easy recall. A file contains all the settings that are shown on the operating screen at the time the file is created. Figure 4-6 shows the MEMORY MENU when there are no files stored, and Figure 4-7 shows the menu when there is one file or more stored.

Creating a New File

Set the operating screen to the desired parameters. This includes temperature or voltage, unit of measure, thermocouple type, reference-junction temperature, offset, and lead material. Next press **MENU** and select MEMORY. When there are no files stored, the only option is to store the current screen setup as a new file using the SAVE AS function and then selecting <NEW> per force.

At this point, enter a name for the current setting. File names can be up to 16 characters long using letters and numbers. Use the right **ARROW KEY** or press the **ENCODER** to append characters to the file name. The file name can be created using the **KEYPAD**, the **ARROW KEYS**, the **ENCODER**, or any combination thereof. Additionally, the +/- key acts as a delete key to erase the character above the cursor (for example, if a file is named BRAIN, placing the cursor under the I and pressing +/- will change the name to BRAN). When **ENTER** is pressed, the current setting becomes the WORKING FILE as indicated on the screen.

To enter more files, press **MENU** (or **ESC** twice) to return to the operating screen, make the desired changes (make sure to press **ENTER** so that the Model 1140A knows that the screen has been permanently updated as indicated by the lack of the blinking cursor) and again press **MENU**, then MEMORY. To overwrite the existing working file, use SAVE (note that the SAVE option is not available unless the operating-screen settings differ from the working file). Otherwise select SAVE AS, then <NEW>, and then enter the new name for the file. When the file name is correct, press **ENTER**. At that time, the newly created file becomes the WORKING FILE.

Opening a File

To open a file, press **MENU**, select MEMORY, OPEN, and then select the file to open. The file selected becomes the working file, and the operating screen is changed to the newly selected screen's settings.

Saving a File

Saving a file uses the current operating screen settings and overwrites the working file. Press **MENU**, select MEMORY, and then SAVE. At this point, the working file has been changed, and the SAVE option on the menu is no longer present.

Saving a File As

To save a file under another name, press **MENU**, select MEMORY, and then SAVE AS. Then select either <NEW> or an existing file name to overwrite. If <NEW> is selected, key in the new file's name as described above. If an existing file is chosen to be overwritten, the user will be prompted to confirm the action.

Renaming a File

To rename a file, press **MENU**, select MEMORY, and then RENAME. Next select the file name to be changed, change it, and press **ENTER**. If it is decided not to change the name, press **ESC**. Either way the file, new name or old, becomes the working file. Return to the operation screen by pressing **ESC** twice or **MENU**.

Operation

Deleting a File

To delete a file, press **MENU**, select MEMORY, and then DELETE. Next select the file name to be deleted and press **ENTER**. Prior to pressing **ENTER**, the user can cancel this operation by pressing **ESC**. After **ENTER** has been pressed, thus deleting the file, the next file in the “stack” becomes the working file. If there are no files stored, the screen will state as much.

```

SEQUENCE MENU
VIEW/START SEQUENCE
INSERT SEQUENCE STEP
DELETE SEQUENCE STEP
MOVE SEQUENCE STEP
DELETE ENTIRE SEQUENCE: 5 STEPS
STEPPING: MANUAL
STEP TIME: 0:00:04.0
REPEAT SEQUENCE: NO

```

Figure 4-8: Sequence Menu

Sequence Menu

Once files have been created, the SEQUENCE MENU provides a powerful tool for the user to create a set of files to be stepped through, either manually or in a timed manner. Up to 31 files can be stored in the sequence; and the user can elect where to start the sequence, either at Step 1 or at some other step. If the sequence is in the manual mode, the user can use the **ENCODER** or **ARROW KEYS** to go backward or forward in the sequence.

When no sequence has been created, the user has the option to INSERT A SEQUENCE STEP, specify whether STEPPING is to be MANUAL or TIMED, and turn on sequence REPEAT.

Inserting a Sequence Step

Press **MENU**, select SEQUENCE, and then INSERT SEQUENCE STEP. Select the file to be inserted from the list of files and press **ENTER**. If the SEQUENCE contains one or more steps, the user is given the option of where to place the file in the SEQUENCE. Use the **ENCODER** or **ARROW KEYS** to point where the file is to go.

Viewing/Starting the Sequence

Once the sequence is created, the user can view it and/or select with which file to start the sequence. Press **MENU**, select SEQUENCE, then VIEW/START SEQUENCE. Highlight the file to start the sequence and press **ENTER**. The sequence will then commence. The sequence step, the number of steps in the sequence, the current file of the sequence, and the time remaining of the current step are shown in an annunciator above the main reading on the operating screen. If stepping is set to manual, MANUAL will be displayed instead of the time remaining.

Moving a Step in the Sequence

Once the sequence has more than one step, steps can be moved in the sequence. Press **MENU**, then select SEQUENCE, then MOVE SEQUENCE STEP. Select the step to be moved, press **ENTER**,

and by using either **ARROW KEYS** or the **ENCODER**, indicate where to insert the step. Complete the move by again pressing **ENTER**.

Deleting a Step in the Sequence

To delete a step in the sequence, press **MENU**, select **DELETE SEQUENCE STEP**, select the step to be removed from the sequence, and press **ENTER** to complete the deletion.

Deleting the Entire Sequence

To delete the entire sequence, press **MENU**, select **DELETE ENTIRE SEQUENCE: 23 STEPS**, press **ENTER**, select **YES** to confirm the deletion and again press **ENTER**.

Stepping and Stepping Time

Stepping can either be timed or manual. If **TIMED** is selected, any valid time from 0.3 seconds to 99 hours: 59 minutes: 59.9 seconds can be set. This sets the time that the Model 1140A is set to each file in the sequence. For example, if the user wants to set up a sequence of 0°C to 100°C in 10°C increments and each sequence step is to last 20 seconds, the time should be set to 00:00:20.0. When incrementing or decrementing time, the tenths of seconds do not spill over to seconds, the seconds to minutes, etc. To set a time of less than one second, set the seconds to any number other than 00, then set the tenths of seconds to any number between 0.3 and 0.9, and then set the seconds, minutes, and hours to 00.

If **MANUAL** is selected, the user can control the sequence steps by either using the **ENCODER** or the **ARROW KEYS**. The up and right **ARROW KEYS** go forward in the sequence, and the down and left **ARROW KEYS** go backward in the sequence. To end using the sequence, press the **ENCODER** or any key except an **ARROW KEY**, select **YES**, and press **ENTER**.

Repeating the Sequence (Timed)

By setting **REPEAT SEQUENCE** to **YES**, the sequence cycle will keep repeating until the user interrupts it by pressing any front-panel key (except the **ARROW KEYS**), selecting **YES**, and pressing **ENTER** to exit the sequence. If **REPEAT SEQUENCE** is set to **NO**, the sequence will be done once, and then the Model 1140A will automatically exit the sequence.

Repeating the Sequence (Manual)

By setting **REPEAT SEQUENCE** to **YES**, the user can cycle through the sequence multiple times (going from the first step to the last and back to the first in a loop, etc.) until exiting the sequence by pressing any front-panel key (except the **ARROW KEYS**) and selecting **YES**. If **REPEAT SEQUENCE** is set to **NO**, the user can go through the cycle and back but not from the last step to the first step. Exit the sequence by pressing any front-panel key (except the **ARROW KEYS**), and selecting **YES**.

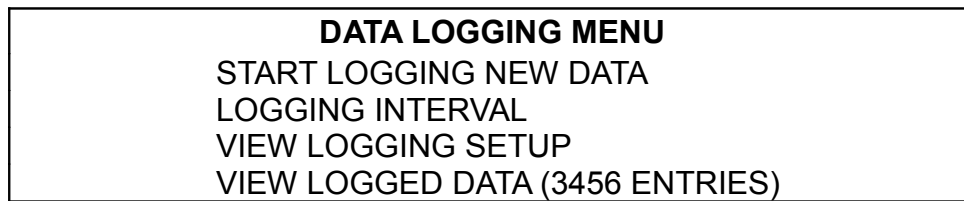

Figure 4-9: Data Logging Menu

Data Logging Menu and Downloading Data

In the meter mode, the Model 1140A has the capability to log, store, display, and download 10,000 data points, each of which contains a date, time, and the data itself. By going to the DATA LOGGING MENU, the user can set the time interval between data points and start logging data. Once data has been stored, the user can view the data on-screen and download the data in various formats.

Data logging is available in units with serial number above 75700.

Initial Setup

Begin data logging by setting all front-panel parameters to the desired settings. If in the temperature mode, these include:

- Thermocouple type
- Thermocouple-offset units (if using alloy connections)
- Thermocouple offset (if using alloy connections)
- Reference-junction-temperature units
- Reference-junction temperature
- Instrument mode (must be METER)
- Output mode (TEMPERATURE)
- System-temperature units
- Material
- Terminals used (if using alloy connections)
- Copper offset units (if using copper connections)
- Copper voltage offset (if using copper connections)
- Autozero enabled
- Autozero temperature offset (if autozero is ON)

If in the voltage mode, these include:

- Instrument mode (must be METER)
- Output mode (VOLTAGE)
- System voltage units
- Material (COPPER)
- Copper offset units
- Copper voltage offset
- Autozero enabled
- Autozero voltage offset (if autozero is ON)

To facilitate setup, once the front-panel settings are complete, the user may want to store the settings as a memory file for later recall using the MEMORY MENU.

Start Data Logging

When the logging interval has been set, upon pressing **ENTER** the user will be asked to confirm that old data can be overwritten. Answer **NO** to return to the **DATA LOGGING MENU** without overwriting existing data. Answer **YES**, and the Model 1140A will begin logging data. One to 10,000 data points can be captured.

Logging Interval

Pressing **ENTER** on this option takes the user to an hours-minute-second display at which the user can select any time-interval setting from one second to 99 hours: 59 minutes: 59 seconds. A setting of 00:00:00 is not allowed. When incrementing or decrementing time, the seconds do not spill over to minutes, and the minutes do not spill over to hours.

Viewing Logged Instrument Setup

This screen will allow the user to view all the setup parameters in place when data logging commenced. It will be displayed in a vertical column that the user can scroll through using either the **ENCODER** or **ARROW KEYS**.

Viewing Logged Data

Data that has been captured can be viewed by selecting this option. The data (time:date:data point) will be displayed in a vertical column that the user can scroll through using either the **ENCODER** or the **ARROW KEYS**. When using the **ARROW KEYS**, holding down the up or down arrow will accelerate the scrolling.

Downloading Data

Once data has been captured, the user can then download it via any installed remote interface. Refer to [Section VI](#) for details.

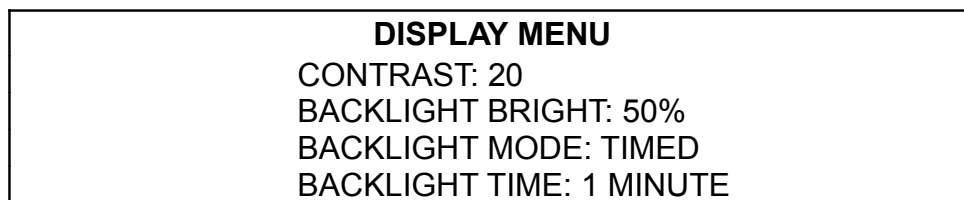

Figure 4-10: Display Menu

Display Menu

The **DISPLAY MENU** allows the user to set the screen contrast and backlight intensity for best viewing. The settings can be changed using either the **ENCODER** or the **ARROW KEYS**. The keyboard is inactive in this menu. Additionally, the user is given the opportunity to set a time after which the backlight will extinguish, if there has been no front-panel activity. Front-panel activity resets the countdown for the timeout interval.

Operation

Contrast

Set the contrast to any number from 0 (lightest) to 40 (darkest). Typically, a setting of 20 to 30 will be adequate for most situations.

Backlight Bright

Set the backlight to any number from 0 (backlight off) to 100 (brightest). Typically, a setting of 45 to 55 is best for viewing.

Backlight Mode⁶

There are three choices for the backlight mode: ON where the backlight is always on, OFF where the backlight is always off, and TIMED for which there are four settings under BACKLIGHT TIME.

Backlight Time⁶

When BACKLIGHT MODE is set to TIMED, the user has four choices for the time duration of the backlight: 30 SECONDS, 1 MINUTE, 2 MINUTES, and 5 MINUTES. Once the front-panel controls have been inactive for the set time, the backlight will extinguish. Any front-panel activity will restart the time. Pressing the **ESC** key will restart the time without changing any front-panel settings.

```

REMOTE MENU
ACTIVE INTERFACE: USB
GPIB SETUP
ETHERNET SETUP
1120 EMULATION MODE: ENABLED
1120 ASTERISK TC TYPE: N-MN175

```

Figure 4-11: Remote Menu

Remote Menu

(See [Section VI](#) for Remote Operation)

The Model 1140A can have up to two optional remote interfaces installed at any one time.⁷ The REMOTE MENU tells the user what interfaces, if any, are installed and which one is active; and it allows the user to set the instrument's remote address.

Model 1120 Remote Emulation

When the Model 1120 Remote Emulation option is installed, the fourth and fifth menu items will appear. Line four allows the user to ENABLE or DISABLE the Model 1120 Remote Emulation mode. When Model 1120 Remote Emulation is enabled, the annunciator 1120 MODE will appear at the upper middle of the display. In this mode, the Model 1140A will only accept remote commands that are formatted in accordance with the Model 1120 remote command set. See

⁶ Backlight mode and time only apply to units with serial numbers above 75700. On earlier units, users may adjust the "Backlight Bright" setting to its lowest value to dim the backlight as much as possible.

⁷ For units with firmware above 4.00, USB is built in and does not count as an optional interface. In older units it was an optional interface.

Section VI. The fifth line allows the user to designate the thermocouple type that will be the “asterisk” type. The Model 1120 holds eight different thermocouple modules, and there are dedicated front-panel keys for seven of them: Types E, J, K, T, S, R, and B. The eighth slot can be either Type N, Type C, or Type Platinel II. This was designated on the display screen of the Model 1120 with an asterisk, and the user has to know what thermocouple type the asterisk represents. In the Model 1140A, any thermocouple type can be designated as the “asterisk” thermocouple type.

The Model 1120 Remote Emulation mode will work over all interfaces offered for the Model 1140A, although this mode was created for customers who were using the Model 1120 and desired to upgrade to the Model 1140A without rewriting remote code for their calibration and production systems. Nearly all of these customers were using the GPIB interface.

When the Model 1120 Remote Emulation option is installed and enabled, standby mode is unavailable.

Changing the active interface

To change the active interface from the REMOTE menu, highlight ACTIVE INTERFACE, press **ENTER**, highlight the desired interface to activate, and again press **ENTER**.

USB Setup

No setup is needed in the Model 1140A to use the USB interface. If using LabVIEW, the Model 1140A is a USB Test & Measurement Class (USBTMC) device on units with firmware above 4.00.

For older units with firmware below 3.99, prior to connecting the Model 1140A to a computer using the USB interface, follow the driver installation instructions in the separate USB Driver Setup PDF, located on the CD that was included with the unit.

GPIB Setup⁸

The only setup necessary for GPIB use is setting the address. To set the address of the GPIB interface, whether it is active or not, highlight GPIB SETUP and press **ENTER**. Then, using the encoder or the arrow keys, enter a valid address (0 to 30) and again press **ENTER**.

Ethernet Setup⁸

DHCP Enabled

Enable DHCP (Dynamic Host Configuration Protocol) to allow adding the Model 1140A to a network with little interaction required. To enable it, highlight ETHERNET SETUP and press **ENTER**. Then using the arrow keys or the encoder, select ENABLE and press **ENTER**. When DHCP is enabled, the IP ADDRESS, NETMASK, GATEWAY, and NAMESERVER are set by a DHCP server on the network.

When DHCP is enabled, the user simply may give the Model 1140A a HOST NAME, which can be blank, and the TELNET PORT number.

⁸ In units with firmware below 3.99, interface setup is accessed by selecting SLOT 1 or SLOT 2, whichever indicates the desired interface.

Operation

Host Name

The HOST NAME is the unique name by which the device is known on the network. To create or change it, highlight HOST NAME and press **ENTER**. Create any name from 0 to 15 characters using the keypad, arrow keys, and the **ENCODER**. Names can include numbers and letters. No blanks or symbols are allowed. To remove a character, place the cursor under the character to be removed and press the **+/-** key. When finished, press **ENTER**.

Telnet Port

The default setting for the TELNET PORT (Telecommunication Network) is 23. Valid port numbers are any between 0 and 65535. To change it, highlight TELNET PORT and press **ENTER**. Although the arrow keys and the **ENCODER** can be used to change the port, use the keypad to directly enter desired port number and then press **ENTER**. If the user wished to use the arrow keys and **ENCODER**, note that number places are added with the left arrow key.

DHCP Disabled

When DHCP is DISABLED, the user must enter additional settings: IP ADDRESS, NETMASK, GATEWAY, and NAMESERVER. These settings should be obtained from the system administrator for the network in which the Model 1140A is connected. To enter them, highlight the desired number, press **ENTER**, key in the number, and again press **ENTER**.

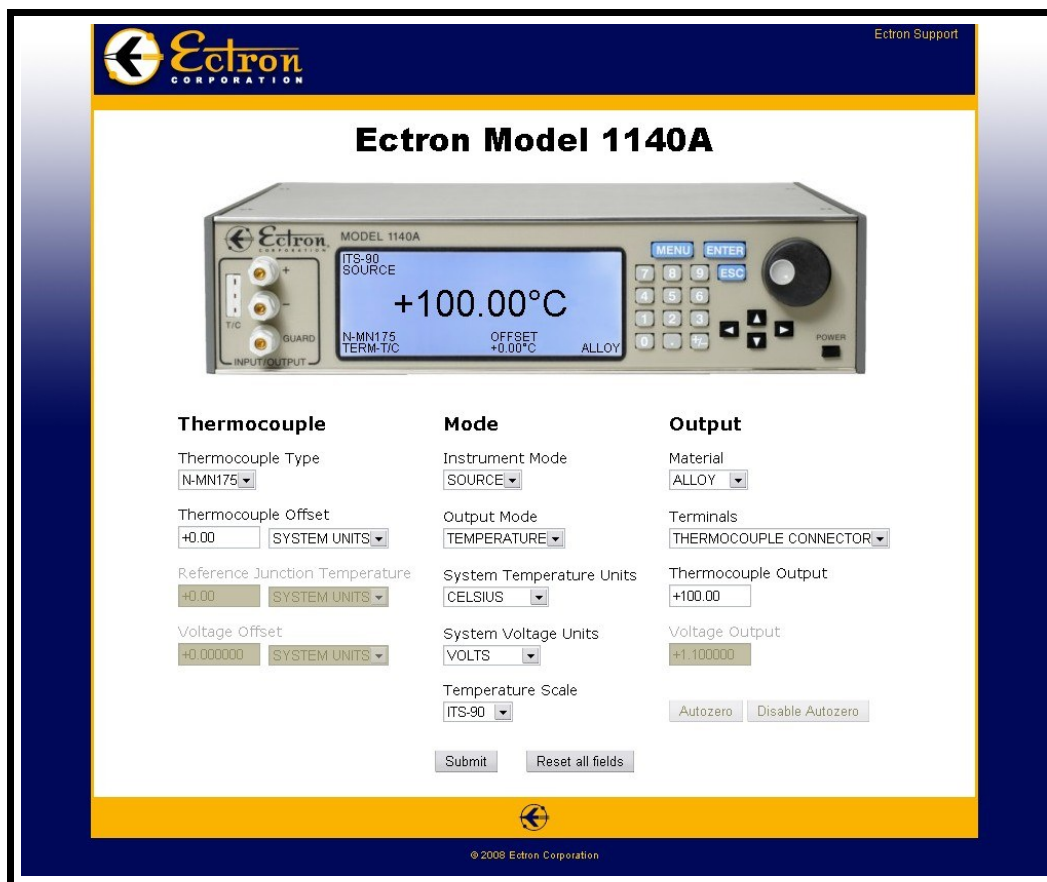

Figure 4-12: Web Browser Using the Ethernet Interface

Browser Screen

Once all the settings have been entered, the user may want to use a web browser to perform remote changes to the Model 1140A. To begin this feature, open the computer's browser. In the address field type in the HOST NAME (default ECTRON1140A) or fully qualified domain name and press the computer's **ENTER**. Once the screen loads, the user can change settings on the computer and click on **SUBMIT** to effect the changes. See Figure 4-12. If Javascript is supported in the browser, the screen will update every second.

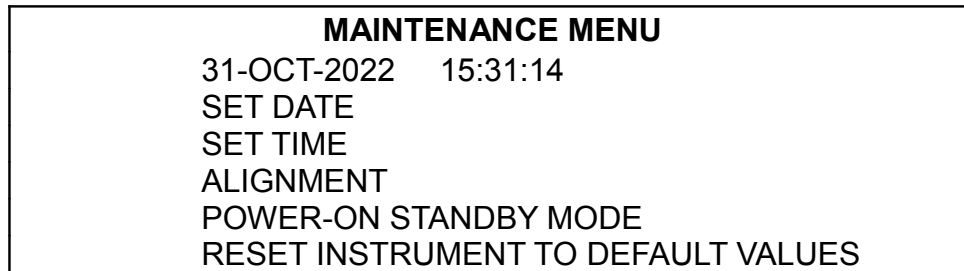

Figure 4-13: Maintenance Menu

Maintenance Menu

Use the MAINTENANCE MENU to SET DATE, SET TIME, and RESET INSTRUMENT TO DEFAULT VALUES. The current settings for date and time are displayed above the menu options. ALIGNMENT will not appear unless the alignment switch is “on.”

Set Date

Selecting SET DATE takes the user to a 100-year calendar (January, 2000 through December, 2099) from which the user can easily set the date using the **ARROW KEYS** or the **ENCODER**.

Set Time

The hours (0 to 23), minutes, and seconds can be set using **ARROW KEYS** or the **ARROW KEYS** with the **ENCODER**. The **KEYPAD** is not active to set time.

Alignment

When the alignment-enable switch (recessed in a square hole in the bottom cover just to the rear of the **KEYPAD**) is switched to the user's right, the ALIGNMENT sub-menu can be accessed. For alignment instructions, see [Section VIII, Alignment](#).

Power-on Standby Mode

This option controls whether the Model 1140A will be in standby mode when first turned on. The default setting is ON. If changed to OFF, the instrument will not enter standby mode on power-up. In either case, the **OPR/STBY (ENTER)** key still toggles standby off or on.

This option became available in firmware 4.43.

Operation

Reset Instrument to Default Values

Selecting this option and then selecting YES with confirmation to reset all settings will reset the Model 1140A to those settings in Table 4-2. Alignment of the instrument, memory and sequence settings, and settings from the DISPLAY MENU and MAINTENANCE MENU are not affected.

Table 4-2: Default Settings

Parameter	Setting
Thermocouple type / Output	K-MN175 ⁹ / 0.00°C
Thermocouple offset units	System units
Thermocouple offset	0.00°C
Reference-junction-temperature units	System units
Reference-junction temperature	0.00°C
Instrument mode	Source
Output mode	Temperature
System temperature units	Celsius (°C)
System voltage units	Volts (V)
Temperature resolution limit	0.01°
Voltage resolution limit	0.1 µV
Temperature scale	ITS-90
Material	Alloy
Terminals	Binding posts ¹⁰
Copper offset units	System units
Copper voltage offset	0.000000 V
Autozero enabled	No
Autozero temperature offset	+0.00°C

<p style="text-align: center;">DIAGNOSTICS MENU KEYPAD TEST LCD TEST ABOUT</p>

Figure 4-14: Diagnostics Menu

Diagnostics Menu

The DIAGNOSTICS MENU is provided for the user to verify that the **KEYPAD** buttons and the LCD display pixels are working properly.

Keypad Test

Select **KEYPAD TEST** to test any front-panel control for proper operation. The screen will indicate any signal received from the front-panel controls, such as 6 **PRESSED**, **ENTER RELEASED**, **DECIMAL POINT HELD**, or **ENCODER TURNED CLOCKWISE**. Press **ESC** when finished.

⁹ Type B-MN175 in firmware versions below 3.39.

¹⁰ Thermocouple Connector in firmware below 3.99.

LCD Test

Select LCD TEST to test all the pixels on the display. Initially, a horizontal bar slowly moves up and down on the screen. By pressing either the up or down **ARROW KEY** or turning the **ENCODER**, the user can manually control the position of the line to more closely observe the display pixels.

About

Select ABOUT to display the versions for the FIRMWARE and the COMPILER, the compile date for the firmware, and the serial number of the unit.

SECTION V

APPLICATIONS

GENERAL

The Model 1140A is a high-accuracy thermocouple simulator-calibrator incorporating the latest circuit design, a fast microcontroller, intuitive and user-friendly software, and many advanced functions. Because this instrument offers a high level of accuracy and resolution, many applications are available not possible with lesser simulators. Some of these are outlined in this section.

FUNCTIONS

The following instrument modes are available selected either by front panel or by remote control:

Source Mode

In the temperature output mode, the Model 1140A becomes a precision thermocouple simulator with six digits of display and resolution to 0.01 degrees.¹¹ Because of this display resolution, even high-temperature signals can have high resolution. For electrically noisy environments, the resolution can be reduced.

For example it is possible to simulate a Type J thermocouple at 1155.55°C. The 6-month accuracy at this setting is $\pm 0.07^\circ\text{C}$.

When sourcing thermocouple voltages (without cold-junction compensation) the resolution is 0.1 μV with six digits of display. An example of its display and resolution capabilities could be simulating a Type J thermocouple at 1150°C and a display of 66,679.2 μV .

In the voltage output mode, it is a precision 0.002% dc source (30-day specification) with 7 digits of display and resolution to 0.1 μV . For example, this allows a ± 9.876543 V signal to be generated with a resolution of 1.0 μV .

Meter Mode

In the temperature output mode, the Model 1140A is a precision thermocouple-measuring meter (auto-ranging digital thermometer) with resolution to 0.01 degrees¹¹ and six digits of display.

In the voltage output mode, it is a precision dc-measuring meter (auto-ranging digital voltmeter) with seven digits of display and resolution to 0.1 μV .

¹¹ In firmware 3.47 and lower, in temperature mode of operation resolution was automatically reduced to 0.1°C when the Seebeck coefficient (change in emf per degree) was less than 10 $\mu\text{V}/^\circ\text{C}$.

CAUTION

The battery pack, if installed, must be charged at least once every two months. If this is not done, the battery-pack voltage may decay beyond its ability to recover.

NOTE

During battery charging, heat may be produced inside the instrument, particularly near the end of the charging process. This changing internal temperature can have a small effect on the unit's output. If the highest accuracy is required, the user may wish to wait until 30 minutes after charging has finished for thermal stabilization.

BATTERY OPERATION¹²

Although operation from either ac power or battery makes virtually no difference to the user, there are some precautions that should be observed. The battery pack is of the nickel-metal hydride (Ni-MH) type which, unlike Ni Cad batteries, should never be allowed to discharge completely. Fortunately, the sophisticated charger circuitry used in this instrument prevents this from happening.

To charge the battery pack optimally, its temperature is continuously monitored. In addition, if its temperature is outside of recommended limits charging is not allowed. Two charge current levels are incorporated. The first is a high-rate charge allowing a three-hour charge time. The second is a lower charge current used to "top off" the battery.

This battery pack can be given a partial charge when necessary although a full charge period should be used periodically to preserve optimum battery life.

Another very important characteristic of the Ni-MH battery is that it should be recharged at least every two months to obtain maximum life. Normal performance can be obtained from the battery over the full temperature range of this instrument: 0°C to 50°C.

For details of the battery-related messages that may appear in the display of the Model 1140A, see [Message Displays](#) in the [Operation](#) section.

CONNECTIONS

Binding posts and a mini-three-pin thermocouple connector are provided for source and measure connections. Four temperature sensors embedded in the front-panel terminals, two in the mini-thermocouple connector and two in the binding posts, allow the Model 1140A to compensate for ambient temperature variations. Despite Ectron's best efforts to minimize errors at these

¹² The rechargeable battery is available for units with serial numbers above 75700.

Applications

terminals, certain thermal conditions can cause measurable errors in both measure and source modes.

Thermocouple Connections

When using thermocouples, the choice of either the binding posts or the mini-connector is up to the user and the application. However, better performance sometimes can be obtained using the binding posts, because their higher thermal mass allows better sensing within each terminal. This would only be a concern when highest possible accuracy is required and ambient conditions are poor. A trade-off is that the greater thermal mass may have a longer initial stabilization time.

For instance, if local conditions include variable air temperature such as operation on a flight line and in addition highest accuracy is required, then slightly more stable results may be obtained when using the binding posts.

Temperature Variation

There are two primary sources of these errors: handling the thermocouple wires or the mini-connector and air flowing past the terminals. Typically these errors are well under 0.1°C although some conditions can increase these errors, and precautions must be taken to maintain the high accuracy of the instrument.

Air that flows past the front-panel terminals from fans or air ducts is a typical source of the problem. The amount of error depends on the temperature of the air and its velocity as well as the thermocouple type and the gage of the wires being used.

Shielding the terminals from air currents will minimize this problem and is usually sufficient. When wires are heated by handling, the usual remedy is to wait for stabilization. When this is not possible consider using smaller gage wire to reduce the effect.

NOTE

When in either source or measure modes using thermocouples, it is necessary to set the instrument to the connector in use since the sensing of temperature of each of the terminals in use is required to precisely cancel temperature effects at these junctions. Setup for the connection in use is accomplished through the Main Menu and its sub-menus.

CONSIDERATIONS

Polarity of Thermocouple Wires

Among the most common mistakes made when working with thermocouple wires is to reverse the wire connections. Use the manufacturer's designation and refer to Table 4-1 and to <http://www.omega.co.uk/techref/colorcodes.html>¹³ to determine the positive and negative wires. The negative wire is usually colored red for the following thermocouple wires: E, J, K, T, R, S, and N.

13 Courtesy of Omega Engineering, Inc.

At the binding posts, the positive wire is always connected to the upper terminal. However, following standard convention, the mini-thermocouple connector is reversed. For this connector, the top pin is negative, and the middle pin is positive.

Shielding and the Guard Terminals

Historically, thermocouple cabling did not include shielding. This was acceptable for accuracies of a few percent but as the requirement for higher accuracy and more resolution has increased, the need for shielding increases. In addition, the preferred wiring is twisted-pair shielded cables. The twisted wires cancel induced noise from magnetic sources while the shield protects from induced voltage noise.

Shielding of signal leads is recommended when high resolution or high accuracy is required. Without shielding noise pickup can be as much as 50 μV . Depending on thermocouple type this can amount to 1°C or to many degrees for low-output thermocouples. The shield should be connected to the guard terminal of either the binding posts or the connector.

Shielded, twisted-pair wiring is recommended when noise-generating sources are near cable runs. Typical noise sources include motors, generators, and electronic equipment emitting high levels of pulse noise. Even the electromagnetic interference (EMI) from fluorescent lights, especially those with electronic ballasts, can add noise when in close proximity to either the thermocouple or dc wiring.

Grounding

The output of the Model 1140A is referenced to an internal floating ground. This ground is isolated from the input power, chassis, and the remote interface. It is usually sufficient to connect the low output terminal on the Model 1140A's front panel to the input ground or common of the instrument that the Model 1140A is feeding. Sometimes it may be desirable to use a separate wire (other than the thermocouple leads) to connect to an instrument ground on the bench.

For safety reasons and for lowest noise, it is important that the chassis of the Model 1140A be connected to an earth ground, as is normally provided by the ac power cord. The Model 1140A contains a power line filter, which diverts noise to earth ground.

ITS-90 and IPTS-68

These temperature scales are defined by the National Institute of Standards Technology. Although the higher-accuracy ITS-90 is the current temperature scale recommended by NIST, many older instruments still use the IPTS-68. To satisfy these needs, Ectron provides both.

When using IPTS-68, the thermocouple types that are normally based on NIST *Monograph 175* are instead based on older NIST standards: Types B, E, J, K, R, S, and T use *Monograph 125* and Type N uses *Monograph 161*.

Offset

Available both in thermocouple and in linear voltage operation, an offset can be added or subtracted from the output. This is normally used when a thermocouple has a known offset; adding this offset allows the Model 1140A to provide higher-accuracy measurements. When an offset is set, OFFSET is noted in the lower middle right of the display, with the value underneath.

Applications

The available range of offset is $\pm 5^{\circ}\text{C}$ for all thermocouple types or ± 11.000 V dc for dc voltages.

The thermocouple offset, accessible through the THERMOCOUPLE → THERMOCOUPLE OFFSET menu, is intended to be an offset at the temperature of the Model 1140A terminals, and is not an offset at the simulated (or measured) temperature.

The offset applied is computed using the Seebeck coefficient for the current thermocouple type, at the temperature of the front-panel terminals in use. As such it can be used to compensate for an error of a thermocouple calibrated at the environment of the Model 1140A, and is not intended to compensate for thermocouple errors at other temperatures.

Note that the sense of the offset value can be thought of as a correction to the actual thermocouple emf. Thus, if the calibrated thermocouple's output was less than the standard emf for that type, the correction applied would need to be positive. On the Model 1140A, a positive value would be entered in the THERMOCOUPLE OFFSET menu.

NOTE

Each thermocouple type has its own offset. If the thermocouple type is changed, for example, from Type E to Type J, the offset that was set for Type E will not affect Type J measurements.

Autozero

Available for both thermocouple and linear voltage operation when using the Model 1140A in the meter mode, an autozero can be commanded by local or remote control. When an autozero is commanded, the readout is forced to a zero reading and further changes in signal are shown as changes around the zero reading. Autozero is noted in the display as AZ and is located in the upper middle of the display.

For example, if monitoring a temperature chamber whose temperature was 1600°C , the user could command an autozero. Immediately the instrument reads zero and thereafter follows the temperature variation of the chamber about zero with a high degree of accuracy and resolution. The readout signals are coupled to the user's interface for data logging or computation as desired.

NOTE

Until an autozero is canceled both the display and the interface data will reflect the change of the autozero.

Low Output Impedance

Unlike many dc or thermocouple calibrators, the Model 1140A offers very low output impedance ($0.05\ \Omega$ maximum) in the source mode at all output levels. This very helpful characteristic provides some important advantages for general operation.

A precision dc source can have loading problems even with high-impedance loads. One very popular high-precision calibrator has an output resistance of $220\ \Omega$ for all voltages under

200 mV. With a 1 M Ω load the error at 100 mV is 20 μ V or 220 ppm, well over its claimed accuracy at this voltage. In contrast, using the Model 1140A the error would be under 0.5 ppm.

Another advantage is that several loads can be simultaneously connected to the output of the Model 1140A when operating as a source. For instance, when operating as a thermocouple simulator, usually several loads can be paralleled with no problem. This instrument allows this practice but most other simulators or precision dc sources do not.

Guard Bands

Guard bands enable test limits to be set to allow for the worst-case measurement error. The use of guard bands in most instances improves the probability that there are no good instruments that are found to be out of specification and no bad ones that are found to be in specification.

Calibrating instruments that use low-output thermocouples (TC's) or those that provide only a small change in emf per degree (Seebeck effect) is most difficult since testing these instruments requires a highly accurate and stable TC simulator.

Because the Model 1140A offers a high level of TC simulation accuracy, guard banding can be reduced giving more assurance that the device-under-test is meeting its specification. For example, if a data system is using Type S thermocouple material, and a test point is required at 1500°C, the nominal TC output is 15,581.67 μ V and the Seebeck coefficient (emf change per degree) is only 12.0369 μ V. A lesser calibrator can provide only a calibration to 0.46°C whereas the Model 1140A has an accuracy of 0.26°C. With accuracy demands increasing, 0.46°C may not be tolerable.

Even for thermocouples in their normally used ranges, the Model 1140A's contribution to error budget allows users virtually to ignore the calibrator's error margins.

SECTION VI

REMOTE OPERATION

GENERAL

The Model 1140A can be controlled remotely via one of the available interfaces: USB, GPIB, Ethernet, and RS-232. Two optional remote interfaces can be installed at any one time, with any one installed interface being active.¹⁴

In this section, commands sent and results received over a remote interface are shown with a gray background.

```
REMOTE MENU
ACTIVE INTERFACE: USB
GPIB SETUP
ETHERNET SETUP
1120 EMULATION MODE: DISABLED
1120 ASTERISK TC TYPE: N-MN175
```

Figure 6-1: Remote Menu

REMOTE MENU

The REMOTE MENU shows the user what interfaces, if any, are installed and which one is active; and it allows the user to adjust any relevant settings for each interface. Refer to the [Remote Menu](#) section of the Operation section for further details on the menu options.

ACTIVATING AND DE-ACTIVATING REMOTE CONTROL

Activating the remote-mode operation of the Model 1140A is typically done automatically by the program(s) associated with remote operation, such as LabVIEW by National Instruments. In the absence of such a program, a lower-level command such as the GPIB command REN (remote enable) can be employed.

When any remote interface is active, the Model 1140A gives priority to remote control over front-panel control. Receipt of any remote command causes the Model 1140A to enter remote mode, and the letters REM are shown in the upper-right corner of the display. These letters blink off momentarily any time a remote command is received.

If any front-panel key is pressed while in remote mode, a warning is displayed and the operator asked whether to return to local mode. Returning to local mode allows front-panel control. However, receipt of any remote command will again place the Model 1140A in remote mode.

¹⁴ RS-232 became available in units with firmware above 4.00. Additionally, in these units USB is built in and does not count as one of the two optional interfaces.

Table 6-1: Remote Command Summary

Command String (SCPI Syntax)	Arguments	Function	Command	* Query
Source Mode				
:SOURce:TEMPerature:VALue	Temperature	Simulation temperature	✓	✓
:SOURce:VOLTag:VALue	Voltage	Source voltage	✓	✓
:OUTPut:OVERload?		Retrieve output overload status		✓
:OUTPut:STANdby **	{ON, OFF}	Toggle standby mode	✓	✓
Meter Mode				
:SENSe:VALue?		Retrieve meter-mode value		✓
Thermocouple				
:INSTrument:THERmocouple:TYPE:CATalog?		Retrieve catalog of thermocouple types		✓
:INSTrument:THERmocouple:TYPE	Thermocouple type	Thermocouple type	✓	✓
:UNIT:THERmocouple:OFFSet	{C, F, R, K, SYSTEM}	Thermocouple offset units	✓	✓
:INSTrument:THERmocouple:OFFSet:VALue	Temperature	Thermocouple offset value	✓	✓
:UNIT:REFJunction	{C, F, R, K, SYSTEM}	Reference-junction units	✓	✓
:OUTPut:REFJunction:VALue	Temperature	Reference-junction temperature	✓	✓
Instrument				
:INSTrument:MODE	{SOUR, METER}	Source or meter mode	✓	✓
:INSTrument:MODE:ENTry	{VOLT, TEMP}	Voltage or temperature mode	✓	✓
:UNIT:TEMPerature	{C, F, R, K}	System temperature units	✓	✓
:INSTrument:TEMPerature:STANdard	{ITS-90, IPTS-68}	System temperature standard	✓	✓
:UNIT:VOLTag	{mV, V}	System voltage unit	✓	✓
Output				
:INSTrument:MATerial	{ALLOY, COPPER}	Thermocouple or copper wire	✓	✓
:INSTrument:TERMinal	{TC, POST}	Output terminal	✓	✓
:UNIT:VOLTag:OFFSet	{mV, V, SYSTEM}	Copper voltage offset units	✓	✓
:INSTrument:VOLTag:OFFSet:VALue	Voltage	Copper voltage offset	✓	✓
:INPut:AZERo		Performs autozero function	✓	
:INPut:AZERo:STATe	OFF	Turn autozero off	✓	✓
:INPut:AZERo:VALue?		Retrieve autozero offset		✓
System				
:STATus:PRESet		Revert user settings to defaults	✓	
:SYSTem:REMote		Place unit in remote control	✓	
:SYSTem:LOCal		Place unit in local control	✓	
:SYSTem:DATE?		Retrieve system date		✓
:SYSTem:TIME?		Retrieve system time		✓
:SYSTem:SERialno? ***		Retrieve unit's serial number		✓
:MEMory:CATalog?		Retrieve memory file catalog		✓
:SYSTem:ERRor?		Retrieve first error from queue		✓
:SYSTem:ERRor:ALL?		Retrieve all errors from queue		✓
:SYSTem:ERRor:CODE?		Retrieve code of next error		✓
:SYSTem:ERRor:CODE:ALL		Retrieve code of all errors		✓
:SYSTem:ERRor:COUNt?		Retrieve count of errors in queue		✓
Data Logging				
:LOG:SETup?		Retrieve log setup conditions		✓
:LOG:DATA?		Retrieve logged data		✓
:LOG:SETup:FIRSt?		Retrieve first log setup line		✓
:LOG:SETup:NEXt?		Retrieve next log setup line		✓
:LOG:DATA:FIRSt?		Retrieve first log data point		✓
:LOG:DATA:NEXt?		Retrieve next log data point		✓
* To query, type a question mark (?) immediately after the command string as shown on query-only commands.				
** Standby mode is available with firmware 4.00 and above.				
*** Serial number query was introduced at firmware version 3.04.				

Remote Operation

Because the Model 1140A gives priority to remote control over front-panel control, continuous or nearly continuous remote commands will essentially lock out the front panel. Therefore, the remote command stream must be stopped before the Model 1140A can be controlled from the front panel.

MODEL 1140A COMMANDS

Ectron Corporation has developed commands that are unique to the Model 1140A. In general, these commands control nearly all functions of the THERMOCOUPLE MENU, the INSTRUMENT MODE MENU, the OUTPUT MENU, and the DATA LOGGING MENU as well as the value of the temperature or voltage being generated (if in source mode). Table 6-1 shows the commands that correspond to the aforementioned menus along with special commands as shown.

Either short commands (shown in capital letters only) or long commands (full words, shown in mixed case) may be used. In reality, commands are not case sensitive.

Commands can be concatenated, but they must be limited to 128 bytes in length including any required termination character. When concatenating commands, place a semicolon, which counts as a byte, between the commands. For USB and Ethernet, a newline (ASCII 0x0A) must be sent as a termination character. GPIB does not require a termination character as it uses hardware EOI (End or Identify) for message termination.

Following are examples and discussion of the commands in Table 6-1.

Source-mode Commands and Queries

Set the Simulation Temperature `:SOURce:TEMPerature:VALue {Temperature}`

{Temperature} must be a valid numeric value representing a temperature for the thermocouple type and system unit of measure currently in use. When the system temperature unit of measure is changed, the Model 1140A will convert the simulation temperature to the new unit of measure. For example if a temperature of 200°C is set, and then the unit of measure is set to °F, the new source value will be 392.

Example: `:SOUR:TEMP:VAL 200`

Example: `:SOUR:TEMP:VAL -23.45`

Query the Simulation Temperature `:SOURce:TEMPerature:VALue?`

Returns the temperature value followed by the system temperature unit of measure as a single character.

Example: `:SOUR:TEMP:VAL?` returns the value displayed, e.g. `+200.00F`.

Set the Source Voltage `:SOURce:VOLTage:VALue {Voltage}`

{Voltage} must be a valid numeric value representing a voltage within the range of the Model 1140A, considering the current offset voltage.

Note that this command is always in volts regardless of the unit of measure setting.

Example: `:SOUR:VOLT:VAL 1.456`

Query the Current Source Voltage `:SOURce:VOLTage:VALue?`

Returns the current source voltage followed by the system voltage unit of measure.

Example: `:SOUR:VOLT:VAL?` returns the output value, e.g. `+1.456000V`.

Query the Overload Status `:OUTPut:OVERload?`

If there is an overload, the Model 1140A returns a 1; if not, a 0.

Example: `:OUTP:OVER?` will return `0` for no overload.

Change Standby Status `:OUTPut:STANdby {Standby Status}`

{Standby Status} must be OFF or ON. This command is available on units with firmware 4.00 and above.

Example: `:OUTP:STAN ON` will put the unit in standby mode

Query the Standby Status `:OUTPut:STANdby?`

Returns OFF or ON. This query is available on units with firmware 4.00 and above.

Example: `:OUTP:STAN?` will return `ON` for standby mode.

Meter-mode Query

Query the Value Measured by the Model 1140A in Meter Mode `:SENSe:VALue?`

This is returned as a string containing the number followed by the unit of measure currently used for that value.

Example: `:SENS:VAL?` returns the presently measured value, e.g. `+234.56C`.

Thermocouple Commands and Queries

Query Available Thermocouple Types `:INSTrument:THERmocouple:TYPE:CATalog?`

Returns a comma-delimited string of available thermocouple types.

Example: `:INST:THER:TYPE:CAT?` returns
`B-MN175,R-MN175,S-MN175,E-MN175,J-MN175,K-MN175,`
`N-MN175,T-MN175,PLII,G,C,D.`

In units with firmware above 4.00 set to IPTS-68 (instead of ITS-90), this query returns
`B-MN125,R-MN125,S-MN125,E-MN125,J-MN125,K-MN125,`
`N-MN161,T-MN125,PLII,G,C,D.`

Set the Thermocouple Type `:INSTrument:THERmocouple:TYPE {Type}`

{Type} must be a type in the catalog of the available thermocouple types (see above).

Note: If the thermocouple type is changed without changing the simulation temperature, an error could result if the current simulation temperature is out of range for the new

Remote Operation

thermocouple type. The same can happen if the simulation temperature is set first but the new simulation temperature is outside the range of the old thermocouple type.

Setting either the thermocouple type or the simulation temperature first will usually resolve the issue, but not always. There are pairs of thermocouple types for which neither the new nor the old simulation temperature will be within range of both new and old thermocouple types.

The solution is to first set the simulation temperature to a temperature from 250°C to 400°C (482°F to 752°F, 523.15 K to 673.15 K, or 941.67°R to 1211.67°R), then change the thermocouple type, and finally set the simulation temperature to the desired value. This range of temperatures is within all supported thermocouple types and hence will not result in an error.

Example: `:INST:THER:TYPE R-MN175` sets the thermocouple to Type R per NIST *Monograph 175*.

Query the Active Thermocouple Type `:INSTrument:THERmocouple:TYPE?`

Returns the thermocouple type currently in use.

Example: `:INST:THER:TYPE?` returns `B-MN175`, for example.

Set the Thermocouple Offset Unit of Measure

`:UNIT:THERmocouple:OFFSet {Temperature unit of measure}`

{Temperature unit of measure} must be C, F, R, K, or SYSTEM. If SYSTEM is entered, the thermocouple offset will use the present system temperature unit of measure. When the offset unit of measure is changed, the offset value may change, e.g. if the value is 4 and the unit of measure is changed from °C to °F, the value will change to 7.2. No change will occur when the unit of measure is changed from °F to °R or from °C to K.

Example: `:UNIT:THER:OFFS C` sets the offset unit of measure to Celsius.

Query the Current Thermocouple Offset Unit of Measure `:UNIT:THERmocouple:OFFSet?`

Returns C, F, R, or K.

Example: `:UNIT:THER:OFFS?` could return `F`.

Set the Offset for the Current Thermocouple Type

`:INSTrument:THERmocouple:OFFSet:VALue {Temperature value}`

{Temperature value} must be within the range of -5 to +5 for temperature in Celsius and Kelvin and -9 to +9 for temperature in Fahrenheit and Rankine. If the offset unit of measure is later changed, the offset value may change: e.g. if the value is 4 and the unit of measure is changed from C to F, the value will change to 7.2. No change will occur when the unit of measure is changed from F to R or from C to K. Note that separate offsets are stored for each thermocouple type.

Example: `:INST:THER:OFFS:VAL 3.4`

Query the Thermocouple Offset Value `:INSTRument:THERmocouple:OFFSet:VALue?`

Returns the offset temperature followed by its unit of measure as a single character.

Example: `:INST:THER:OFFS:VAL?` could return `+1.45C`.

Set the Reference-junction Temperature Unit of Measure

`:UNIT:REFJunction {Unit of measure}`

{Unit of measure} must be C, F, R, K, or SYSTEM. If SYSTEM is entered, reference-junction unit of measure will be the present system unit of measure. When the reference-junction temperature unit of measure is changed, the reference-junction temperature value will change: e.g. if the value is 25 and the unit of measure is changed from C to F, the value will change to 77.

Example: `:UNIT:REFJ F` sets the reference-junction temperature unit of measure to Fahrenheit.

Query the Reference-junction Temperature Unit of Measure `:UNIT:REFJunction?`

Returns C, F, R, or K.

Example: `:UNIT:REFJ?` returns `C`.

Set the Reference-junction Temperature `:OUTPut:REFJunction:VALue {Temperature}`

{Temperature} must be a valid numeric value representing a temperature for the thermocouple type and reference-junction unit of measure currently in use. When the reference-junction unit of measure is changed, the offset value may change, e.g. if the value is 4 and the unit of measure is changed from C to F, the value will change to 39.2. Note that the reference-junction temperature is only used when the output entry mode and output material differ in nature (temperature and copper connections, or voltage and alloy connections).

Example: `:OUTP:REFJ:VAL 77` sets the reference-junction temperature to 77.

Query the Reference-junction Value `:OUTPut:REFJunction:VALue?`

This will return the reference-junction temperature followed by its unit of measure as a single character.

Example: `:OUTP:REFJ:VAL?` could return `+77F`.

Instrument Commands and Queries

Set the Instrument Mode `:INSTRument:MODE {Mode}`

{Mode} must be SOURCE or METER.

Example: `:INST:MODE SOURCE` sets the mode to source.

Query the Present Instrument Mode `:INSTRument:MODE?`

Returns SOURCE or METER.

Remote Operation

Example: `:INST:MODE?` returns `SOURCE`.

Set the Output Entry Mode `:INSTrument:MODE:ENTRy {Mode}`

{Mode} must be `VOLT` (for voltage) or `TEMP` (for temperature).

Example: `:INST:MODE:ENTR TEMP` sets the instrument entry mode to temperature.

Query the Entry Mode `:INSTrument:MODE:ENTRy?`

Returns either `VOLT` (for voltage) or `TEMP` (for temperature).

Example: `:INST:MODE:ENTR?` returns `VOLT`.

Set the System-temperature Unit of Measure `:UNIT:TEMPerature {Unit of measure}`

Valid entries for {Unit of Measure} are `C`, `F`, `R`, and `K`. Any temperature except output offset temperatures will be converted to the new system temperature unit of measure.

Example: `:UNIT:TEMP F` sets the temperature unit of measure to Fahrenheit.

Query the System-temperature Unit of Measure `:UNIT:TEMPerature?`

Returns `C`, `F`, `R`, or `K`.

Example: `:UNIT:TEMP?` may return `C`.

Set the Instrument Temperature Standard

`:INSTrument:TEMPerature:STANdard {Standard}`

{Standard} must be `ITS-90` or `IPTS-68`.

Note: In units with firmware above 4.00, changing the instrument's temperature standard will change the names used for thermocouple Types `B`, `E`, `J`, `K`, `N`, `R`, `S`, and `T`. Refer to [Thermocouple Commands and Queries](#) above for details.

Example: `:INST:TEMP:STAN ITS-90` sets the International Temperature Scale of 1990.

Query the Instrument Temperature Standard `:INSTrument:TEMPerature:STANdard?`

Returns `ITS-90` or `IPTS-68`.

Example: `:INST:TEMP:STAN?` returns `ITS-90`.

Set the System Voltage Unit of Measure `:UNIT:VOLTage {Voltage unit of measure}`

{Voltage unit of measure} must be `mV` (millivolts) or `V` (volts).

Example: `:UNIT:VOLT V` sets the system voltage unit of measure to volts.

Query the System Voltage Unit of Measure `:UNIT:VOLTage?`

Returns `mV` or `V`.

Example: `:UNIT:VOLT?` returns MV.

Output Commands and Queries

Set the Material to be Connected `:INSTrument:MATerial {Material}`

Valid inputs for {Material} are ALLOY or COPPER.

Example: `:INST:MAT ALLOY` sets the unit to work with alloy connections.

Query the Material of the Wires with which the Model 1140A is set to operate
`:INSTrument:MATerial?`

Example: `:INST:MAT?` would return either COPPER or ALLOY.

Activate the connector to be used `:INSTrument:TERMinal {Connector}`

{Connector} must be TC (for the thermocouple connector) or POST (for the white binding posts). This command only pertains to alloy connections. Temperature sensors are embedded in the connectors, and only one set, either the thermocouple connector or the binding posts, is active at a time.

Example: `:INST:TERM TC` activates the thermocouple connector.

Query the Output Terminal in use `:INSTrument:TERMinal?`

Example: `:INST:TERM?` returns TC for the thermocouple connector or POST for the binding posts.

Set the Unit of Measure for Copper Material Offset

`:UNIT:VOLTage:OFFSet {Voltage unit of measure}`

{Voltage unit of measure} must be mV (for millivolts), V (for volts), or SYSTEM. If SYSTEM is commanded, the Model 1140A will use the system voltage unit of measure.

Example: `:UNIT:VOLT:OFFS MV` sets the unit of measure to mV (millivolts).

Query the Current Unit of Measure for the Copper Material Offset `:UNIT:VOLTage:OFFSet?`

Returns either MV (for millivolts) or V (for volts).

Example: `:UNIT:VOLT:OFFS?` returns V.

Set the Offset for Copper Material `:INSTrument:VOLTage:OFFSet:VALue {Voltage}`

{Voltage} must be in the range of -11 to +11. Note that this command is always in volts regardless of the unit of measure setting.

Example: `:INST:VOLT:OFFS:VAL .0001` for 100 μ V.

Example: `:INST:VOLT:OFFS:VAL -2E-2` for -20 mV.

Remote Operation

Query the Offset for Copper Material `:INSTrument:VOLTagE:OFFSet:VALue?`

Returns the voltage followed by the copper voltage offset unit of measure.

Example: `:INST:VOLT:OFFS:VAL?` might return `+0.020000MV`.

Perform an Autozero Function `:INPut:AZERo`

This command is only valid when the instrument mode is METER.

Example: `:INP:AZER`. The instant that this command is sent, the Model 1140A will read 0 V (or mV, °C, °F, °R, or K).

Disable the Autozero Offset `:INPut:AZERo:STATe {OFF}`

This command does not change stored value of the autozero.

Example: `:INP:AZER:STAT OFF`

Query the Autozero State `:INPut:AZERo:STATe?`

Returns OFF or ON.

Example: `:INP:AZER:STAT?` returns `OFF` (autozero is off).

Query the Current Autozero Offset Value `:INPut:AZERo:VALue?`

This command returns a voltage or temperature depending on the current entry mode. It is returned along with the corresponding voltage or temperature system unit of measure.

Example: `:INP:AZER:VAL?` returns `+26C`.

System Commands and Queries

Reset the Model 1140A to Default Values `:STATus:PRESet`

The following command will reset the Model 1140A to its default values. Not affected are screen contrast and brightness, contents of the MEMORY MENU and the SEQUENCE MENU, and calibration parameters. Table 4-2 lists the default values.

Example: `:STAT:PRES` resets the unit to default settings.

Place the Unit in Remote Control `:SYSTem:REMote`

Example: `:SYST:REM` places the unit under remote control.

Place the Unit in Local Control `:SYSTem:LOCAl`

Example: `:SYST:LOC` places the unit under local control.

Query the System Date `:SYSTem:DATE?`

Example: `:SYST:DATE?` might return `31-OCT-2022`.

Query the System Time `:SYSTem:TIME?`

Example: `:SYST:TIME?` might return `15:07:37`.

Query the Serial Number of the unit `:SYSTem:SERialno?`

Example: `:SYST:SER?` might return `12345`.

Query the Unit's Memory Files `:MEMory:CATalog?`

Returns a comma-separated list of file names.

Example: `:MEM:CAT?` might return `test1,test2`.

Query the First Error in the Queue `:SYSTem:ERRor?`

This command pops the oldest error out of the queue and returns its numeric code as well as a brief description, separated by a comma. Refer to [Table 6-2](#) for error codes.

Example: `:SYST:ERR?` might return `-100,Command error`.

Table 6-2: Model 1140A Error Codes

Code	Description Returned	Explanation
0	No error	
101	Temperature out of range	The simulation temperature being programmed is out of range for the current thermocouple type.
102	Reference junction temp out of range	The reference-junction temperature being programmed is out of range for the current thermocouple type.
103	Temp out of range for thermocouple	The current simulation temperature is out of range for the thermocouple type being programmed.
104	Ref jct out of range for thermocouple	The current reference-junction temperature is out of range for the thermocouple type being programmed.
105	Voltage out of range	The voltage being programmed is out of range.
106	Output overload	The Model 1140A is incapable of supplying the programmed output.
107	Thermocouple invalid for temperature scale	The thermocouple type commanded is not available in the current temperature scale.
-100	Command error	Unrecognized query, command, or command parameter.
-101	Command not allowed in Standby mode	A command was received which could not be acted on in Standby mode.
-315	Nonvolatile memory error	An internal memory error occurred at startup.
-350	Queue overflow	An overflow occurred in the error queue; the older error(s) have been discarded.

Remote Operation

Query All Errors in the Queue :SYSTem:ERRor:ALL?

Example: :SYST:ERR:ALL? might return:
-100, Command error
105, Voltage out of range
etc.

Query the First Error Code in the Queue :SYSTem:ERRor:CODE?

This command pops the oldest error out of the queue and returns its numeric code. Refer to [Table 6-2](#) for error codes.

Example: :SYST:ERR:CODE? might return -100.

Query All Error Codes in the Queue :SYSTem:ERRor:CODE:ALL?

Example: :SYST:ERR:CODE:ALL? might return:
-100
105

Query the Count of Errors in the Queue :SYSTem:ERRor:COUNT?

Example: :SYST:ERR:COUN? might return 2.

Data Logging Queries

Data logging is available in units with serial number above 75700.

Query the data-logging setup :LOG:SETup?

Returns all the parameters associated in the setup.

Example: :LOG:SET? returns:
START DATE, 31-OCT-2022
START TIME, 16:06:01
LOG INTERVAL, 0:01:00
LOG ENTRIES, 726
OUTPUT MODE, TEMPERATURE
THERMOCOUPLE TYPE, J-MN175
TERMINALS, BINDING POSTS
MATERIAL, ALLOY
THERMOCOUPLE OFFSET TEMP, +0.00C
TEMPERATURE SCALE, ITS-90

Query Logged Data :LOG:DATA?

This query returns all date, time, and data points, one line per reading. The line items are delimited (separated) by commas for easy conversion to a spreadsheet. Each line is numbered.

Example: `:LOG:DATA?` returns:
 1, 31-OCT-2022, 16:06:01, +24.53C
 2, 31-OCT-2022, 16:07:01, +24.54C
 3, etc.

The next four commands allow the user to query the setup and the data points one line at a time.

Query the First Line of Data Logging Setup `:LOG:SETup:FIRst?`

Example: `:LOG:SET:FIR?` returns `START DATE, 31-OCT-2022`

Query the Next Line of Data Logging Setup `:LOG:SETup:NEXt?`

Returns the next line of the setup in the same order that `:LOG:SETup?` lists them.

Example: `:LOG:SET:NEX?` may return `THERMOCOUPLE TYPE, J-MN175`.

Query the First Line of Logged Data `:LOG:DATA:FIRst?`

Example: `:LOG:DATA:FIR?` may return
 1, 31-OCT-2022, 16:01:01, +23.53C.

Query the Next Line of Logged Data `:LOG:DATA:NEXt?`

Returns the next line of logged data following the previously retrieved data using this query.

Example: `:LOG:DATA:NEX?` may return
 2, 31-OCT-2022, 16:02:01, +23.54C.

MODEL 1120 REMOTE EMULATION OPTION

Background

The Model 1120 Remote Emulation option was developed for those customers who have been controlling their Model 1120's on a GPIB bus with dedicated programming. The Model 1120 Remote Emulation mode allows them to connect the Model 1140A to their existing systems and have the Model 1140A function in those systems. Ectron does not recommend writing new code for the Model 1140A using the Model 1120 Emulation mode.

While the Model 1120 was controlled remotely with either GPIB or RS-232, the Model 1140A can be controlled by Ethernet and USB as well in the Model 1120 Remote Emulation mode. It is anticipated by Ectron that customers who require this option will be using GPIB.

Limitations

When a Model 1140A is equipped with the Model 1120 Remote Emulation option, and it is enabled, the Model 1140A will respond to Model 1120 remote commands with certain limitations as described below.

Remote Operation

Packet Delimiter

The Models 1120 and 1140A both detect the EOI GPIB bus flag as a packet delimiter. In addition, the Model 1140A also treats carriage return and newline characters as packet delimiters. This is only significant if remotely editing output values over multiple packets (see below).

Command Processing

The Model 1120 processes commands sequentially regardless of whether they were received over the remote interface or entered at the front panel. This allows users to send parts of command strings over the remote interface and interleave commands from the front panel. The Model 1120 Remote Emulation mode on the Model 1140A does not support this feature, and does not interpret front-panel keys in the same way as remote characters. Thus remote commands and front-panel keys cannot be interleaved.

Numeric Editing

The Model 1120 allows remote editing of the numeric value of the current output. Sending the 'W' character deletes the right-most digit currently on the display, and sending multiple 'W' characters removes multiple digits from the right end of the value. These can then be replaced with numeric characters sent over the interface. This feature allows changing only the last few digits without having to send the entire value.

The current numeric value is always shown on the Model 1120, and the sign flashes to indicate that the value is being edited or entered. The Model 1140A supports these operations, but the output value shown in large characters on the display does not change in real time to show editing in progress. When editing is completed within one remote packet, only the completed value is displayed. If remote packets are received that contain editing commands but no subsequent 'Z' or 'X' character, the partially edited value is shown just above the large digits in the middle of the display. This value will continue to be displayed until a 'Z' or 'X' character is received, which can aid in debugging the editing process. When a packet containing a 'Z' or 'X' character is received, the edited value is no longer displayed.

Storage and Recall of Saved Values

Storage and recall of saved values ('X' or 'Y' character) are not supported. The 'X' character is discarded without error. Any unprocessed edits to the output value are lost when the 'X' character is received. The reference-junction temperature cannot be set using the 'X8' command nor can the output be set using the 'X0' command.

GPIB Parallel and Serial Poll and Local Lockout

GPIB parallel poll and local lockout are not supported. Serial polling is allowed.

Default Thermocouple Type at Power-up

In the Model 1140A the thermocouple type at power-up is determined by what thermocouple type was selected when the instrument was powered down. There are no thermocouple modules in the Model 1140A with which to determine the default thermocouple type.

Meter and Source Modes

Since the Model 1120 only operated in source mode, the Model 1140A only operates in source mode when the Model 1120 Remote Emulation mode is enabled. If this mode is enabled and the user attempts to change the instrument mode to meter, the following error message will appear on the screen:

```
METER MODE NOT ALLOWED  
IN 1120 EMULATION MODE  
  
PRESS ANY KEY TO CONTINUE
```

If the Model 1140A is in meter mode when the user enables the Model 1120 Remote Emulation mode, the Model 1140A will switch to source mode.

Standby Mode

When the Model 1120 Remote Emulation mode is enabled, standby mode is unavailable.

Model 1120 Remote Control Operation

Commands are sent to the Model 1120 as if the user were entering them at the front panel. For example, the string of 4.581MUZ would return 4.581 mV in copper mode. If an error is made in the command, the Model 1120 returns an Error Code. In the Model 1140A using Model 1120 Remote Emulation, when an incorrect command is sent the applicable Error Code is returned to the front panel between the annunciator 1120 MODE and the large value in the middle.

Table 6-3 gives all the valid commands (keystrokes) of the Model 1120 that are emulated in the Model 1140A. Although the STO (store) and RCL (recall) commands will not return an error, they are not supported by the Model 1140A.

Table 6-3: Model 1120 Remote Commands

Key	Remote-programming Code
0	0
1	1
2	2
3	3
4	4
5	5
6	6
7	7
8	8
9	9
.	.
+	+
-	-
C	C
F	F

Key	Remote-programming Code
mV	M
V	V
Cu	U
Aly	S
STO/RCL	Not supported
CLR	W
EXECUT	Z
E	E
J	J
K	K
T	T
S	S
R	R
B	B
*	*

Errors

The possible errors the can occur are:

- E1 The Temperature selected is beyond the specification for the selected thermocouple type.
- E2 The voltage selected is beyond the voltage range of the Model 1140A.

SECTION VII THEORY OF OPERATION

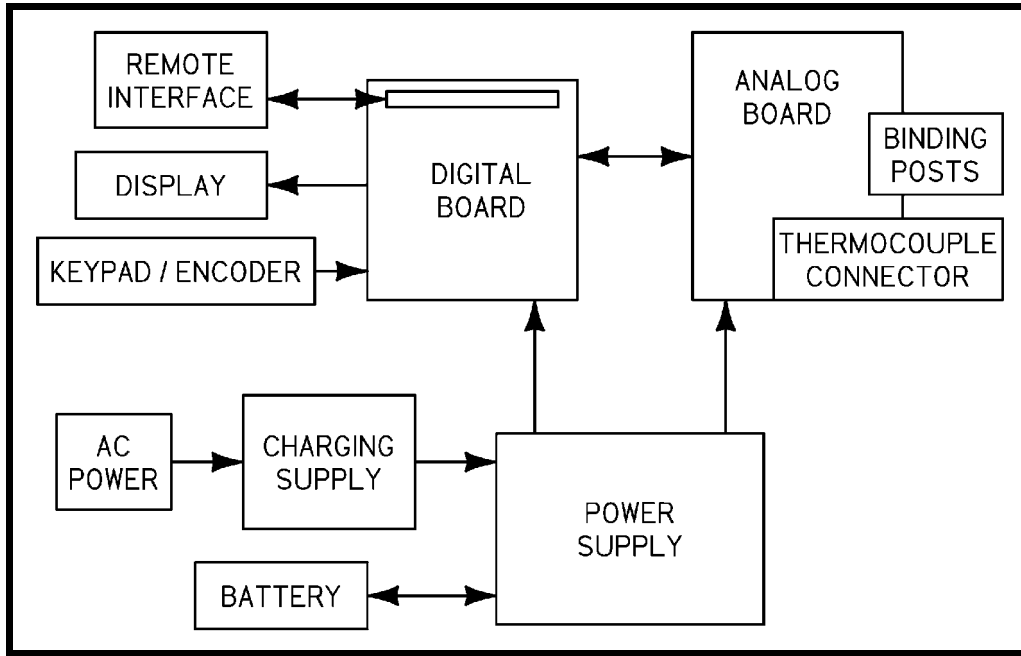

Figure 7-1: Model 1140A Block Diagram

OPERATING MODES

The Model 1140A has four basic modes of operation: thermocouple simulator, thermocouple meter, precision voltage source, and precision voltmeter. Additionally, the instrument can support connections to user wires of either thermocouple alloy or copper.

The following equations give the equivalent output for each of the above eight conditions. In the equations, the function $f_{cn}(T)$ represents the theoretical emf that would be produced by a thermocouple of the selected type at temperature T . The inverse function $f_{cn}^{-1}(V)$ represents the temperature equivalent to the voltage V .

Thermocouple Simulator (Alloy Output)

The general equation for the Model 1140A when it is simulating a thermocouple in the alloy mode is

$$T_{OUTPUT} = T_{SIMULATED} + T_{OFFSET},$$

where T_{OUTPUT} is the equivalent temperature of the simulated thermocouple, $T_{SIMULATED}$ is the user-specified simulation temperature shown on the display, and T_{OFFSET} is the offset temperature set in the THERMOCOUPLE → THERMOCOUPLE OFFSET menu.

Theory of Operation

Precision Voltage Source (Copper Output)

The general equation for the Model 1140A when it is used as a precision linear voltage source in the copper mode is

$$V_{OUTPUT} = V_{SOURCE} + V_{OFFSET},$$

where V_{OUTPUT} is the voltage produced at the terminals, V_{SOURCE} is the user-specified voltage shown on the display, and V_{OFFSET} is the offset voltage set in the OUTPUT → COPPER VOLTAGE OFFSET menu.

Thermocouple Meter (Alloy Input)

The general equation for the Model 1140A when it is used to measure temperature using a thermocouple as its input is

$$T_{METER} = T_{INPUT} - T_{OFFSET} - T_{AZ},$$

where T_{METER} is the measured temperature shown on the display, T_{INPUT} is the theoretical temperature of an ideal thermocouple connected to the terminals, T_{OFFSET} is the thermocouple offset set in the THERMOCOUPLE → THERMOCOUPLE OFFSET menu, and T_{AZ} is the autozero offset temperature (if autozero is enabled).

Precision Voltmeter (Copper Input)

The general equation for the Model 1140A when it is used as a precision voltmeter is

$$V_{METER} = V_{INPUT} - V_{OFFSET} - V_{AZ},$$

where V_{METER} is the measured voltage shown on the display, V_{INPUT} is the input voltage applied at the terminals, V_{OFFSET} is the offset voltage set in the OUTPUT → COPPER VOLTAGE OFFSET menu, and V_{AZ} is the autozero offset voltage (if autozero is enabled).

Thermocouple Simulator (Copper Output)

The general equation for the Model 1140A when it is used as a precision thermocouple voltage source in the copper mode is

$$V_{OUTPUT} = f_{cn}(T_{SIMULATED}) - f_{cn}(T_{REFJCN}) + V_{OFFSET},$$

where V_{OUTPUT} is the voltage produced at the output terminals, $T_{SIMULATED}$ is the equivalent temperature of the simulated thermocouple, T_{REFJCN} is the temperature of the simulated reference junction set in the THERMOCOUPLE → REF JCT TEMP menu, and V_{OFFSET} is the offset voltage set in the OUTPUT → COPPER VOLTAGE OFFSET menu.

Thermocouple Meter (Copper Input)

The general equation for the Model 1140A when it is used to measure emf's in terms of temperature in the copper mode is

$$T_{METER} = T_{INPUT} + T_{REFJCN} - T_{AZ} - f_{cn}^{-1}(V_{OFFSET}),$$

where T_{METER} is the measured temperature shown on the display, T_{INPUT} is the theoretical temperature of an ideal thermocouple connected to the terminals, T_{REFJCN} is the temperature of the

simulated reference junction set in the THERMOCOUPLE → REF JCT TEMP menu, T_{AZ} is the autozero offset temperature (if autozero is enabled), and V_{OFFSET} is the offset voltage set in the OUTPUT → COPPER VOLTAGE OFFSET menu.

Precision Voltage Source (Alloy Output)

The general equation for the Model 1140A when it is used as a precision voltage source in the alloy mode is

$$V_{OUTPUT} = V_{SOURCE} - f_{cn}(T_{REFJCN}) + f_{cn}(T_{OFFSET}),$$

where V_{OUTPUT} is the voltage produced at the output terminals, V_{SOURCE} is the user-specified voltage shown on the display, T_{REFJCN} is the temperature of the simulated reference junction set in the THERMOCOUPLE → REF JCT TEMP menu, and T_{OFFSET} is the offset temperature set in the THERMOCOUPLE → THERMOCOUPLE OFFSET menu.

Precision Voltmeter (Alloy Input)

The general equation for the Model 1140A when it is used as a precision voltmeter in alloy mode is

$$V_{METER} = V_{INPUT} + f_{cn}(T_{REFJCN}) - f_{cn}(T_{OFFSET}) - V_{AZ},$$

where V_{METER} is the measured voltage shown on the display, V_{INPUT} is the input voltage applied at the terminals, T_{REFJCN} is the temperature of the simulated reference junction set in the THERMOCOUPLE → REF JCT TEMP menu, T_{OFFSET} is the offset temperature set in the THERMOCOUPLE → THERMOCOUPLE OFFSET menu, and V_{AZ} is the autozero offset voltage (if autozero is enabled).

Thermocouple Offset

The thermocouple offset, accessible through the THERMOCOUPLE → THERMOCOUPLE OFFSET menu, is intended to be an offset at the temperature of the Model 1140A terminals, and is not an offset at the simulated (or measured) temperature.

The offset applied is computed using the Seebeck coefficient for the current thermocouple type, at the temperature of the front-panel terminals in use. As such it can be used to compensate for an error of a thermocouple calibrated at the environment of the Model 1140A, and is not intended to compensate for thermocouple errors at other temperatures.

Note that the sense of the offset value can be thought of as a correction to the actual thermocouple emf. Thus, if the calibrated thermocouple's output was less than the standard emf for that type, the correction applied would need to be positive. On the Model 1140A, a positive value would be entered in the THERMOCOUPLE OFFSET menu.

HARDWARE IMPLEMENTATION

Firmware

All operations of the Model 1140A are controlled by firmware flashed onto the digital board. The firmware performs the following tasks:

- Manages the user interface including the front-panel controls and display.
- Monitors the temperature of the instrument and each front-panel terminal.
- Monitors battery state.
- Controls the output of the digital-to-analog converter (DAC) on the analog board.
- Manages instrument alignment.
- Controls the meter-mode feedback loop.
- Logs meter-mode readings for later retrieval.
- Manages the remote interface.

The firmware communicates directly with any remote interface(s) plugged into the digital board. The presence of the interface board is detected at power up and the appropriate configuration made at that time. The active remote interface is periodically checked for traffic and the appropriate response made.

The battery state is monitored via the battery charge controller on the power supply board. All other tasks are performed via the analog board.

Front-panel Assembly

The front-panel assembly contains the output binding posts, thermocouple connector, display, **KEYPAD**, and **ENCODER**. Its function is to provide mechanical support for these components. It also contains the faceplate and front-panel legend.

The keypad board contains the keypad controller, which scans the **KEYPAD** for key presses or **ENCODER** rotations and sends that information to the digital board firmware via a ribbon cable.

Analog Assembly

In response to firmware commands, the analog assembly produces output voltages, measures the temperature of the analog board, measures the temperature of each of the binding posts and thermocouple connector pins, measures the meter-mode input, measures the alignment system output, and stores alignment data in nonvolatile memory.

System firmware commands are received through a serial link that passes through isolators on the power-supply board. The firmware also retrieves readings from the analog board via this same link. An absent or unplugged analog assembly is detected by the firmware and an error message displayed at startup.

Storage of alignment data is done in EEPROM memory located on the analog assembly. Communication with this memory is done via 6-pin ribbon cable J10 directly from the digital assembly. If this memory malfunctions or fails to be detected at power-up, an error is displayed.

Source Mode

In the Model 1140A, source-mode operation is accomplished using a voltage reference, digital-to-analog converter (DAC), and output buffer (see Figure 7-2).

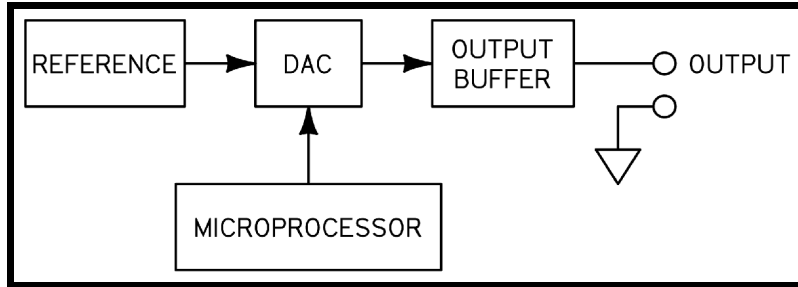

Figure 7-2: Source-mode Operation Diagram

As can be seen in the figure, the DAC passes a fraction of the reference voltage to the output buffer and on to the instrument output. Firmware in the microprocessor decides what fraction of the voltage should be passed to the output, based on user settings, output terminal temperature, and the reference equations for the thermocouple type in use.

Meter Mode

As can be seen in Figure 7-3, meter-mode operation adds only a small amount of complexity, an error amplifier.

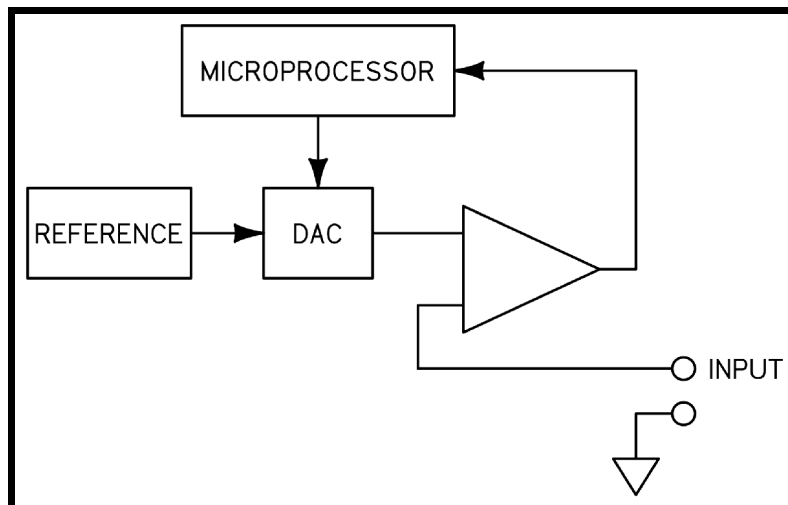

Figure 7-3: Meter-mode Operation Diagram

During meter-mode operation, the positive input terminal is routed to an error amplifier that informs the microprocessor of the difference between the input and the DAC output. The microprocessor then adjusts the DAC output to minimize the difference between it and the input.

Optional Battery

The battery consists of sixteen nickel-metal hydride cells connected in series, a temperature sensor, and fuse. The temperature sensor output is monitored by the charge controller to determine battery condition and when to terminate a charge cycle.

Charging a battery from the fully discharged condition normally takes about 2.5 hours.

Theory of Operation

Battery run time should be greater than six hours from full charge with the display backlight off. If run time is seen to be less than this, the ac power should be momentarily interrupted, then plugged back in for at least 2.5 hours to allow for a full battery charge.

Power-supply Assembly

The Model 1140A power-supply assembly contains the battery charging circuit, dc-to-dc converter, and analog power supplies.¹⁵

Battery Charging Circuit

The charging circuit consists of a charge controller and associated circuitry. When ac power is applied to the unit and it is turned on, operation does not involve the batteries. In this manner, the unit can operate on line power with fully discharged batteries.

The charge controller initiates a charge cycle whenever the unit is plugged in and the battery voltage is low enough to warrant charging. Charging will not start if the battery temperature is below 5°C or above 45°C. If the battery temperature is outside this range, TEMP FLT will be shown on the display. Once the battery temperature has returned to within limits, charging will begin if the battery requires it. If the battery pack fails, charging will not start and BATT FLT will be shown on the display.

Once the battery is charging, it can be terminated due to over or under temperature, over or under battery voltage, if the charging takes too long, and of course if the battery reaches full charge. When the battery reaches full charge, the display indicates CHARGED. If the charge terminates for any of the other reasons, BATT FLT or TEMP FLT is indicated on the display.

If either of these fault conditions is indicated and the Model 1140A is not at room temperature, the unit should be returned to room temperature and ac power momentarily interrupted to see if the fault recurs. If the fault recurs, it may indicate a defective battery.

When the battery charge reaches a low state, the display flashes LOW BATT to warn that there is approximately ½ hour of running time remaining.

Dc-to-dc Converter

The dc-to-dc converter circuitry encompasses an inverter and controller, transformer, rectifiers, and filters. The converter operates at high frequency and is regulated to produce a constant voltage to the analog power supplies.

As the power supply shuts down due to low battery, the dc-to-dc converter alerts the microprocessor so it can ensure that no data is lost as power shuts down. On restoration of power, normal operation resumes. If the power supply fails to properly restore power the display indicates POWER FAILURE. This should never be seen and is an indication of a failure in the power-supply circuitry.

Analog Power Supplies

The analog power supplies regulate and filter several voltages for the analog circuitry. This power is fed to the analog assembly for use in producing the required voltages and measurements.

¹⁵ The rechargeable battery is available for units with serial numbers above 75700. Older units do not have a charging supply; in those units the ac input power connects directly to the power-supply assembly.

SECTION VIII

ALIGNMENT

GENERAL

The Model 1140A is a self-aligning instrument. Once voltage alignment and terminal alignment have been performed, the instrument is ready for use. There are no potentiometers to set or resistors or capacitors to select. Allow a minimum 30 minute warm-up before performing the alignment procedure.

EQUIPMENT REQUIRED

- Ten-volt dc standard: Fluke Model 732B or equivalent. The uncertainty of the voltage must be $<75 \mu\text{V}$ (for a minimum test-accuracy ratio, TAR, of 4:1) and be within the range of 9.9 V dc to 10.1 V dc.
- Shorting bar or cable: Pomona Electronics Model 5145 or equivalent.
- Null detector/microvoltmeter: Keithley Model 155 or equivalent. This unit must be capable of resolving $1 \mu\text{V}$ dc.
- Low-thermal cable, Pomona 1756-24 or equivalent.
- Ice-point bath: Hart Model 9101 zero-point dry well or equivalent. A properly made and maintained distilled-water ice bath can also be used. An uncertainty of 0.01°C is required.
- Calibrated Type T thermocouple (24 AWG recommended) with its error at 26°C , if any, known to the nearest tenth of a microvolt. [Appendix B](#) provides a procedure to calibrate a thermocouple. If copper wires are attached to the thermocouple, the copper ends should be shorted together. The insulation on the thermocouple wire ends should be stripped back approximately 0.4" (10 mm).
- *Optional:* Cover to shield terminals from air flow, such as Ectron P/N 114-523-01.
- *Optional:* For units with firmware version 4.40 and above, the following items from the [Calibration](#) may also be used during alignment:
 - Digital multimeter (DMM), Hewlett Packard Model 3458A (with Option 02) or equivalent.
 - Four-wire Type E thermocouple (24 AWG recommended), calibrated at 26°C with known microvolt error and with bare-wire ends for alloy and copper wires. [Appendix B](#) provides a procedure to calibrate a thermocouple. The insulation on the thermocouple wire ends should be stripped back approximately 0.4" (10 mm).

PRELIMINARY

On the bottom panel of the Model 1140A, set the alignment switch (recessed in a square hole just to the rear of the **KEYPAD**) to the right to enable alignment.

Alignment

VOLTAGE ALIGNMENT

From the MAIN MENU, select MAINTENANCE, ALIGNMENT, and then VOLTAGE ALIGNMENT. The user should note that if any alignment step is aborted by pressing the **ESC**ape key, any new voltage-alignment data will be lost, and the instrument will revert to the previous alignment data.

DAC (Digital-to-analog Converter) Bit Alignment

As directed on the screen, connect the shorting bar or cable to the Model 1140A binding posts and press **ENTER**. Positive and negative DAC bits will be aligned.

Divider Gain Alignment

When the DAC bit alignment is complete, the Model 1140A will automatically perform the divider gain alignment. When it is completed, the technician is directed to remove the shorting bar from the binding posts and press any key to continue.

Source-mode Zero Alignment

The dividers discussed in this paragraph are internal and invisible to the user. The 128:1 divider is active from 0 V to about 0.087 V, the 8:1 divider is active from about 0.087 V to about 1.375 V, and the 1:1 divider is active from 1.375 V to 11 V. As directed on the screen, connect the Model 1140A binding posts to the null detector using the low-thermal cable and then press **ENTER**. The first zero setting is for the 128:1 divider. Using the front-panel controls, adjust the displayed value up or down until the null detector reads $0 \mu\text{V} \pm 0.5 \mu\text{V}$, then press **ENTER**. Repeat the process for the 8:1 divider and the 1:1 divider. For the 8:1 and 1:1 dividers, $0.5 \mu\text{V}$ may be unattainable. Simply set it as close to $0 \mu\text{V}$ as possible. The zero error in the 8:1 and 1:1 dividers is a small percent of the total error budget for those two ranges. When complete, remove the null-detector connections from the Model 1140A and press any key to continue.

Meter-mode Zero Alignment

As directed on the screen, connect the shorting bar to the Model 1140A binding posts and press **ENTER**. When the operation is complete, remove the shorting bar and press any key to continue.

LSB (Least-significant Bit) Alignment

NOTE

The user should try to minimize the time spent connecting the ten-volt standard. If excessive time elapses (a minute or more) between the appearance of the prompt and when **ENTER** is pressed, the 10 V alignment of the unit may produce poor results.

Ensure there is no connection to the Model 1140A and press **ENTER** to continue. In about five seconds, the technician will be directed to connect the ten-volt standard to the Model 1140A binding posts using the low-thermal cable and observing positive polarity. Key in the actual voltage of the voltage standard to the nearest tenth of a microvolt and again press **ENTER**.

When directed, remove the ten-volt connection from the Model 1140A and press **ENTER** to continue.

After about five seconds, the technician will be directed to connect the ten-volt standard using reverse polarity. Key in the actual reading of the voltage standard to the nearest tenth of a microvolt and press **ENTER** (unless two voltage standards are used, this will be same number but with negative polarity as that number used above). Again, the user should minimize the delay time involved. When this alignment step is completed, the user is directed to remove all connections to the Model 1140A and to press any key to continue.

Meter-mode Sensitivity Alignment

As directed on the screen, connect the shorting bar to the Model 1140A binding posts and press **ENTER** to continue. When the alignment step is complete, remove the shorting bar and press any key to continue.

This completes the voltage alignment.

TERMINAL ALIGNMENT

The terminal alignment should be performed after the voltage alignment. Ensure that the alignment switch (located recessed in a square hole in the bottom cover just to the rear of the **KEYPAD**) is to the right to enable alignment. From the **MAIN MENU**, select **MAINTENANCE**, **ALIGNMENT**, and then **TERMINAL ALIGNMENT**. The user should note that if any alignment step is aborted, any new terminal-alignment data will be lost.

When **ENTER** is pressed, the technician is prompted to install the shorting bar on the binding posts. Once this is done press **ENTER** again.

When prompted on the screen, connect a Type T thermocouple (with its error, if any, known in microvolts) to the binding posts. Immerse the other end in either an ice bath of distilled water or electronic ice-point set to 0°C. If copper wires are attached to the thermocouple, ensure that the copper ends are shorted. Optionally, cover the terminals to shield them from air flow.

Enter the offset error, in microvolts, of the thermocouple at 26°C.

A stabilization period of 5–10 minutes is recommended at this point. When ready, press **ENTER**. Once **ENTER** is pressed, the Model 1140A will commence a countdown of two minutes before making any necessary corrections. This will be true for all four thermocouple connections: two on the binding posts and two on the thermocouple connector.

When the previous step is complete, the technician is prompted to reverse the thermocouple leads at the binding posts and again to key in the offset error of the thermocouple. (If the same thermocouple is used, this value should already be displayed on the screen with no further correction needed.) Again, a stabilization period is recommended after connecting the thermocouple and before pressing **ENTER**.

The above sequence is then repeated using the thermocouple connector in place of the binding posts. The orientation of the thermocouple connector is the reverse of the binding post: the top connection is the negative connection, the middle connection is positive, and like the binding posts, the bottom connection is guard. Insert the bare wire ends all the way into the holes.

Alignment

Thermocouple Alloy Corrections (Optional)

This section applies only to units with firmware version 4.40 and above, or version 3.55.

Set up the Model 1140A and equipment according to the instructions for binding post readings in the [Thermocouple Alloy Tests](#) portion of the calibration procedure. If an out-of-tolerance reading is found on the binding posts, it may be corrected as follows.

1. From the MAIN MENU, select MAINTENANCE, ALIGNMENT, and then BINDING POST CORRECTION.
2. Convert the Model 1140A's error from microvolts to degrees Celsius. For a Type E thermocouple, the conversion is:

$$\text{Error in } ^\circ\text{C} = (\text{error in } \mu\text{V}) \times 0.0164^\circ\text{C}/\mu\text{V}.$$

3. Negate the polarity of the error to produce the correction amount. For example, if the DMM reads 1.3 μV above the expected value, the correction is -0.021°C .
4. Add the correction from Step 3 to the value displayed on the screen and enter the result as the new correction. Digits up to the thousandths place may be entered.
5. Press **ENTER** and verify that the reading on the DMM has changed by the desired amount.

Repeat this section using the thermocouple connector instead of binding posts. If a correction is needed, select THERMOCOUPLE CONNECTOR CORRECTION in Step 1.

SECTION IX CALIBRATION

GENERAL

Prior to performing this calibration procedure the Model 1140A the user should become familiar with its operation as described in [Section IV](#) of the Instruction Manual. If a parameter is not mentioned in a setup, it is assumed that it is set to the proper setting when the settings of the Model 1140A are restored to their defaults. This procedure should be followed in the order presented. Deviation from it may result in an incorrect setting that is not specifically addressed in this procedure but is addressed when RESET INSTRUMENT TO DEFAULT VALUES is performed. Note that changes to the output using the **ARROW KEYS** and the **ENCODER** occur in real time. When the **KEYPAD** is used, the user must press **ENTER** for the change to occur. Allow a minimum 30 minute warm-up before performing the calibration procedure.

REQUIRED EQUIPMENT

The equipment listed will ensure a test-accuracy ratio (TAR) of greater than 4:1 for all measurements. If the user substitutes another instrument, care should be taken to ensure a TAR of at least 4:1 for all measurements.

- Digital multimeter (DMM), Hewlett Packard Model 3458A (with Option 02) or equivalent.
- Precision Voltage Source, Fluke 5700A or equivalent.
 - *Note:* A less accurate voltage source may be used if its output is measured with a DMM that has sufficient accuracy, and the DMM's reading is used as the expected value for each meter-mode test.
- Four-wire Type E thermocouple (24 AWG recommended), calibrated at 26°C with known microvolt error and with bare-wire ends for alloy and copper wires. [Appendix B](#) provides a procedure to calibrate a thermocouple. The insulation on the thermocouple wire ends should be stripped back approximately 0.4" (10 mm).
- Ice-point bath: Hart Model 9101 zero-point dry well or equivalent. A properly made and maintained distilled-water ice bath can also be used. An uncertainty of 0.01°C is required.
- Low-thermal cable, Pomona 1756-24 or equivalent.
- Shorting bar or cable: Pomona Electronics Model 5145 or equivalent.
- *Optional:* Cover to shield terminals from air flow, such as Ectron P/N 114-523-01.

TEST REPORTS

The calibration procedure below is designed for use with the test reports given in [Appendix A](#) of this manual. Select the test report corresponding to the time since the unit was last aligned. The user may want to print a blank copy of that report prior to beginning. If a custom test report is used instead, some steps may need to be changed.

Calibration

PROCEDURE

Preliminary Setup

1. Turn on the Model 1140A and allow a minimum 30-minute warm-up.
2. In the MAINTENANCE MENU, select RESET INSTRUMENT TO DEFAULT VALUES and then select YES.

Linear-voltage-tests Setup

Program the Model 1140A as follows:

1. In the INSTRUMENT MODE MENU, set OUTPUT MODE to VOLTAGE.
2. In the OUTPUT MENU, set MATERIAL to COPPER.
3. In the OUTPUT MENU, set TERMINALS to BINDING POSTS.
4. The operating screen should be as shown in Figure 9-1.

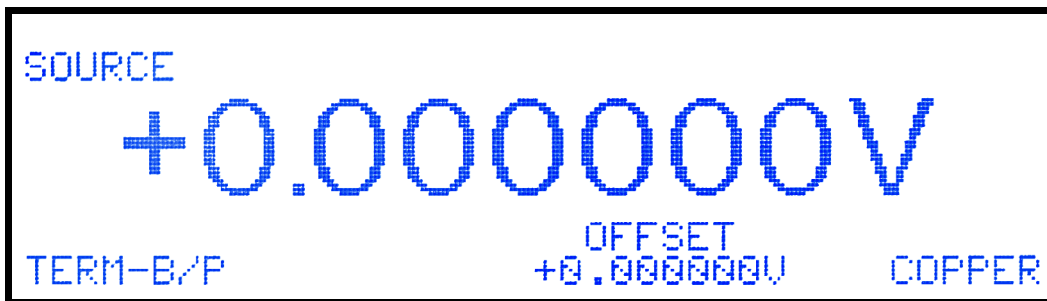

Figure 9-1: Initial Operating Screen for Voltage Tests

Ensure the DMM has had a proper warm-up, and then set it as follows. If a different DMM is used, follow its manufacturer's instructions to measure the voltages with adequate resolution and accuracy.

1. Reset the DMM.
 - a. Press the blue key.
 - b. Press the Reset key.
2. Press the DCV key to select dc volts.
3. Set the power line cycles to 200.
 - a. Press the NPLC key.
 - b. Key in 200.
 - c. Press the Enter key.
4. Set the number of digits to 8.
 - a. Press the blue key.
 - b. Press the N key.
 - c. Press the 8 key.
 - d. Press the Enter key.

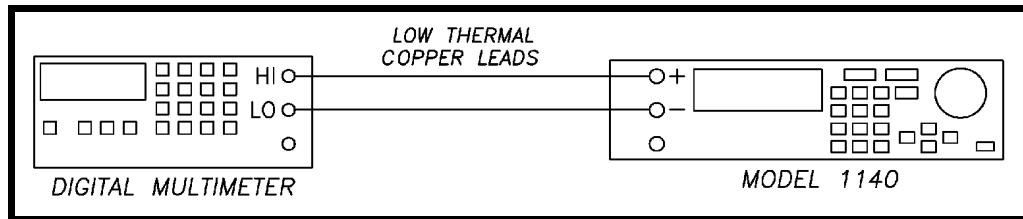

Figure 9-2: Setup for Source Tests

Linear-voltage Tests in Source Mode

1. Connection the Model 1140A to the DMM using the low-thermal cable as is shown in Figure 9-2.
2. For each of the linear-voltage tests on the test report that has a unit of volts:
 - a. Set the Model 1140A to the specified voltage using the **ARROW KEYS**, **ENCODER**, or **KEYPAD**.
 - b. Measure and record the output.
 - c. Ensure each reading is within the tolerance specified.
3. In the INSTRUMENT MODE MENU, set SYSTEM VOLTAGE UNITS to MILLIVOLTS.
4. Continue as in Step 2, but measuring the millivolt values.

Linear-voltage Tests in Meter Mode

1. In the INSTRUMENT MODE MENU, set INSTRUMENT MODE to METER.

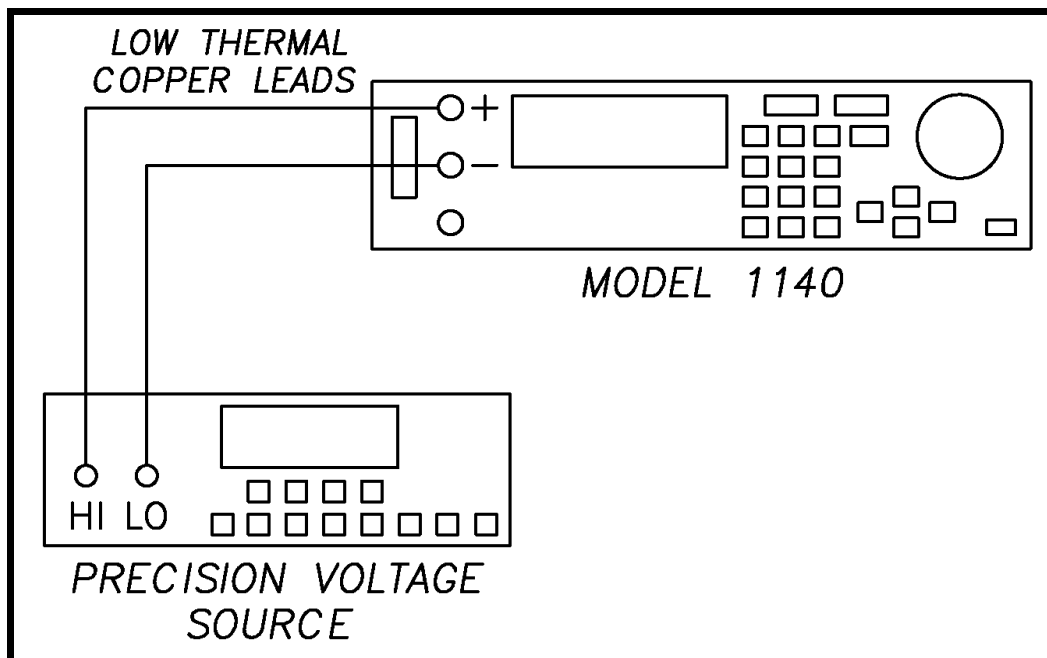

Figure 9-3: Setup for Meter Tests

Calibration

2. Set the precision voltage source for dc volts and connect it to the Model 1140A as is shown in Figure 9-3 using low-thermal leads.
3. For each of the non-zero linear-voltage tests on the test report that has a unit of millivolts:
 - a. Program the precision voltage source to the specified voltage.
 - b. Record the reading on the Model 1140A display.
 - c. Ensure that each is within the tolerance shown.
4. For the 0 mV test:
 - a. Disconnect the low-thermal cable from the Model 1140A.
 - b. Connect a shorting bar.
 - c. Record the reading on the Model 1140A display.
 - d. Ensure that it is within specification.
5. In the INSTRUMENT MODE MENU, set SYSTEM VOLTAGE UNITS to VOLTS.
6. Reconnect the precision voltage source to the Model 1140A.
7. Continue as in Step 3, but measuring the test points that are given in volts.
8. Disconnect the Model 1140A from the voltage source.

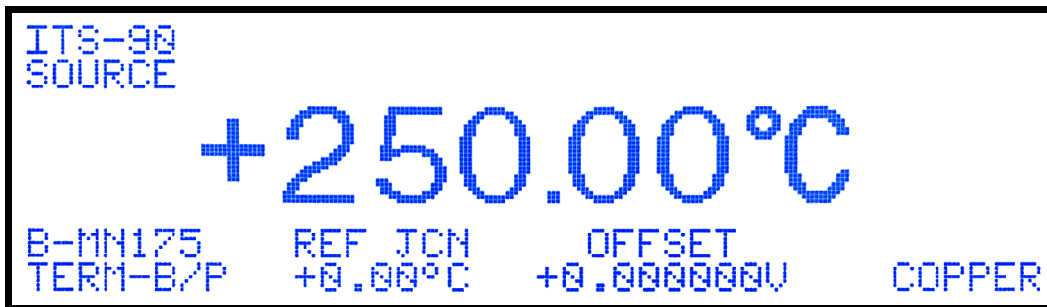

Figure 9-4: Initial Operating Screen for Temperature Tests

Thermocouple Voltage Tests

1. Connect the equipment as is shown in Figure 9-2.
2. In the INSTRUMENT MODE MENU, set INSTRUMENT MODE to SOURCE.
3. In the same menu, set OUTPUT MODE to TEMPERATURE.
4. At the main operating screen, set the output temperature to 250°C.
5. In the THERMOCOUPLE MENU, set THERMOCOUPLE TYPE to B-MN175.
6. The operating screen should be as shown in Figure 9-4.
7. For each of the Celsius readings of thermocouple type B-MN175:
 - a. Program the Model 1140A to the temperature indicated in the test report.
 - b. Record each reading on the DMM.
 - c. Ensure that it is within tolerance.

8. In the INSTRUMENT MODE MENU, set SYSTEM TEMPERATURE UNITS to FAHRENHEIT.
9. Repeat Step 6, but with the Fahrenheit readings.
10. For each of the remaining thermocouple voltage tests:
 - a. Set the Model 1140A to the temperature, THERMOCOUPLE type, and SYSTEM TEMPERATURE UNITS as necessary.
 - b. Record each reading on the DMM.
 - c. Ensure that each is within tolerance.

Thermocouple Alloy Tests

Program the Model 1140A as follows:

1. In the MAINTENANCE MENU, select RESET INSTRUMENT TO DEFAULT VALUES and then select YES.
2. In the THERMOCOUPLE MENU, set THERMOCOUPLE TYPE to E-MN175.
3. In the OUTPUT MENU, set TERMINALS to BINDING POSTS.
4. The Model 1140A operating screen should be as shown in Figure 9-5.



Figure 9-5: Operating Screen for Thermocouple Alloy Tests

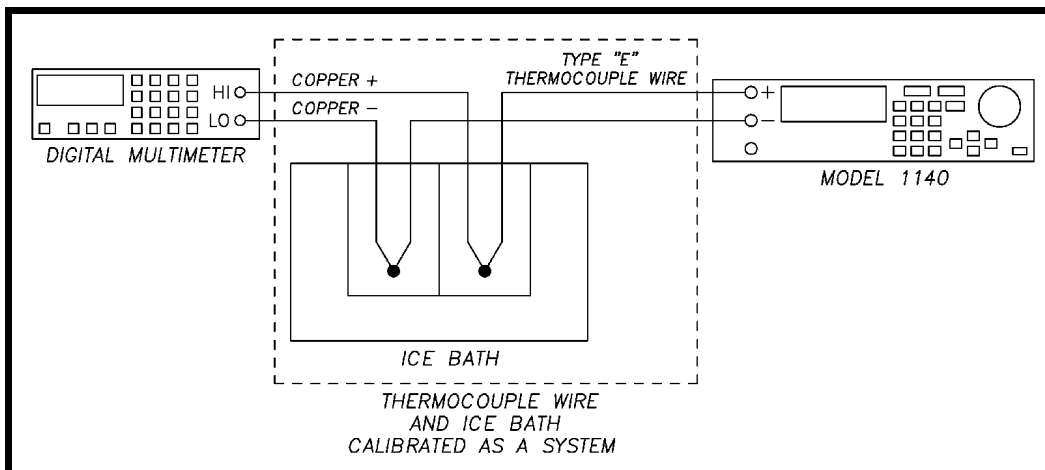

Figure 9-6: Setup for Alloy Test at Binding Posts

Calibration

5. Observing proper polarity, connect the equipment as shown in Figure 9-6. Ensure that the cold junction of the thermocouple is fully immersed in the ice bath. Optionally, cover the terminals to shield them from air flow.
6. Allow at least one minute for stabilization (to allow any thermal emf's created when connecting the equipment to subside); a 5-minute stabilization period is recommended.
7. Note the reading on the DMM.
8. Calculate the test result as follows:

$$(\text{DMM Reading}) - (\text{known error of thermocouple at } 26^{\circ}\text{C})$$

9. Record the result and ensure that it is within the tolerance specified.
10. Remove the thermocouple from the binding posts.
11. In the OUTPUT MENU, set TERMINALS to THERMOCOUPLE CONNECTOR.

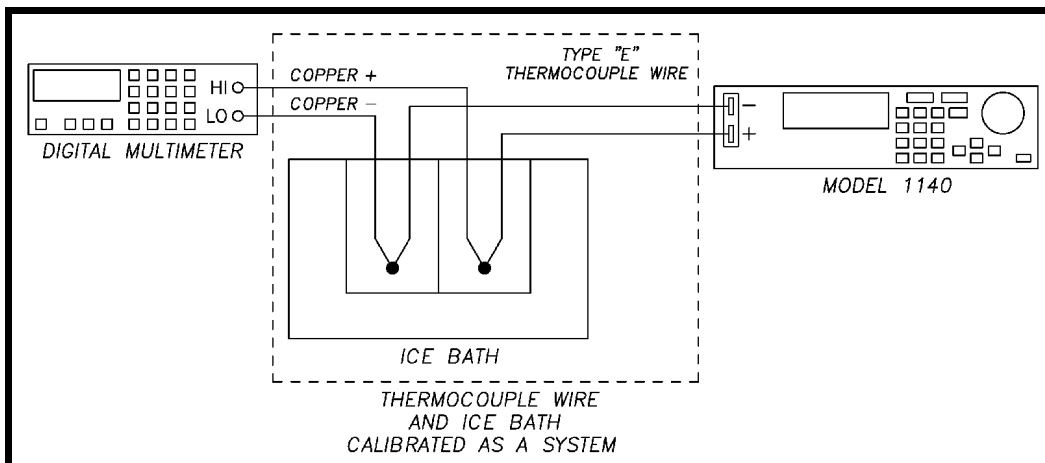

Figure 9-7: Setup for Alloy Test at Thermocouple Connector

12. Connect the Type E thermocouple to the Model 1140A thermocouple connector, inserting the bare wire ends all the way into the holes. Optionally, cover the terminals to shield them from air flow.
13. Allow at least one minute for stabilization (to allow any thermal emf's created when connecting the equipment to subside); a 5-minute stabilization period is recommended.
14. Note the reading on the DMM.
15. Calculate the test result as follows:

$$(\text{DMM Reading}) - (\text{known error of thermocouple at } 26^{\circ}\text{C})$$

16. Record the result and ensure that it is within the tolerance specified.

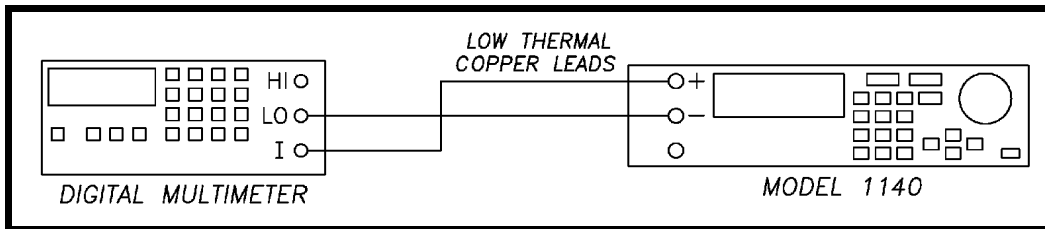

Figure 9-8: Setup for Output-current Test

NOTE

During the following test, the Model 1140A will normally display the OVERLOAD annunciator on the screen; this does not indicate a malfunction.

Output-current Test

1. Connect the DMM to the binding posts using copper leads as shown in Figure 9-8.
2. Press the DCI key to set the DMM to measure milliamperes.
3. In the MAINTENANCE MENU, select RESET INSTRUMENT TO DEFAULT VALUES and then select YES.
4. In the INSTRUMENT MODE MENU, set OUTPUT MODE to VOLTAGE.
5. In the OUTPUT MENU, set MATERIAL to COPPER.
6. In the OUTPUT MENU, set TERMINALS to BINDING POSTS.
7. Set the Model 1140A for +1 V dc output using the **ENCODER**, the **ARROW KEYS**, or **KEYPAD**.
8. The DMM must read between +50 mA dc and +100 mA dc. Record the reading and ensure that it is within specification.
9. Set the Model 1140A for -1 V dc output.
10. The DMM must read between -50 mA dc and -100 mA dc. Record the reading and ensure that it is within specification.

This completes the calibration procedure.

APPENDIX A

CALIBRATION TEST REPORTS

Sample calibration test reports for the Model 1140A are provided on the following pages for testing within 30 days, six months, or one year from the time of calibration. The Expanded Measurement Uncertainty column is blank for the user to calculate the expanded uncertainty, based on the equipment and conditions under which the instrument is aligned and calibrated.

Note: The expected voltages given below for thermocouple types C, D, G, and PL II apply to units with firmware versions 3.47 and above. If calibrating a unit with earlier firmware, contact Ectron Technical Support to request an alternate test report.

Ectron Model 1140A Calibration Test Report Thirty-day Specifications, ITS-90

Customer _____	Date _____
Address _____	Serial Number _____
_____	Report Number _____
_____	Other Identifier _____

Procedure Model 1140A Instruction Manual, [Section IX](#)

Linear-voltage Tests

Voltage	Source Reading	Meter Reading	Tolerance	Expanded Measurement Uncertainty
11.00000 V	V	V	10.999779 V to 11.000221 V	_____
-11.00000 V	V	V	-11.000221 V to -10.999779 V	_____
-10.00000 V	V	V	-10.000201 V to -9.999799 V	_____
10.00000 V	V	V	9.999799 V to 10.000201 V	_____
5.000000 V	V	V	4.999899 V to 5.000101 V	_____
-5.000000 V	V	V	-5.000101 V to -4.999899 V	_____
-2.500000 V	V	V	-2.500051 V to -2.499949 V	_____
2.500000 V	V	V	2.499949 V to 2.500051 V	_____
1.377000 V	V	V	1.3769715 V to 1.3770285 V	_____
-1.377000 V	V	V	-1.3770285 V to -1.3769715 V	_____
-1.373000 V	V	V	-1.3730285 V to -1.3729715 V	_____
1.373000 V	V	V	1.3729715 V to 1.3730285 V	_____
500.0000 mV	mV	mV	499.9890 mV to 500.0110 mV	_____
-500.0000 mV	mV	mV	-500.0110 mV to -499.9890 mV	_____
-88.0000 mV	mV	mV	-88.0028 mV to -87.9972 mV	_____
88.0000 mV	mV	mV	87.9972 mV to 88.0028 mV	_____
85.0000 mV	mV	mV	84.9973 mV to 85.0027 mV	_____
-85.0000 mV	mV	mV	-85.0027 mV to -84.9973 mV	_____
0.0000 mV	μV	μV	-1.0 μV to 1.0 μV	_____

Ectron Model 1140A Calibration Test Report Thirty-day Specifications, ITS-90

Report Number _____

Thermocouple-voltage Tests (Source Mode)

Type	Temperature	Reading	Tolerance	Expanded Measurement Uncertainty
B-MN175	400°C	786.5 μ V	785.1 μ V to 787.9 μ V	
B-MN175	800°C	3153.6 μ V	3152.1 μ V to 3155.1 μ V	
B-MN175	1600°C	11263.0 μ V	11261.4 μ V to 11264.6 μ V	
B-MN175	500°F	317.1 μ V	315.7 μ V to 318.5 μ V	
B-MN175	1215°F	2147.0 μ V	2145.6 μ V to 2148.4 μ V	
B-MN175	3092°F	12432.5 μ V	12430.9 μ V to 12434.1 μ V	
C	1100°C	20070.8 μ V	20069.0 μ V to 20072.6 μ V	
C	1600°C	28242.8 μ V	28240.8 μ V to 28244.8 μ V	
C	2300°C	36931.0 μ V	36928.9 μ V to 36933.1 μ V	
C	1000°F	9392.8 μ V	9391.2 μ V to 9394.4 μ V	
C	3000°F	28960.7 μ V	28958.7 μ V to 28962.7 μ V	
C	4100°F	36548.0 μ V	36545.9 μ V to 36550.1 μ V	
D	200°C	2602.0 μ V	2600.5 μ V to 2603.5 μ V	
D	1700°C	31093.3 μ V	31091.3 μ V to 31095.3 μ V	
D	2250°C	38854.8 μ V	38852.6 μ V to 38857.0 μ V	
D	200°F	1058.0 μ V	1056.6 μ V to 1059.4 μ V	
D	3200°F	32072.3 μ V	32070.3 μ V to 32074.3 μ V	
D	4000°F	38350.5 μ V	38348.3 μ V to 38352.7 μ V	
E-MN175	-175°C	-8121.1 μ V	-8122.7 μ V to -8119.5 μ V	
E-MN175	0°C	0.0 μ V	-1.4 μ V to 1.4 μ V	
E-MN175	950°C	72602.7 μ V	72599.8 μ V to 72605.6 μ V	
E-MN175	-150°F	-5287.3 μ V	-5288.8 μ V to -5285.8 μ V	
E-MN175	32°F	0.0 μ V	-1.4 μ V to 1.4 μ V	
E-MN175	1400°F	57870.0 μ V	57867.4 μ V to 57872.6 μ V	

Ectron Model 1140A Calibration Test Report Thirty-day Specifications, ITS-90

Report Number _____

Thermocouple-voltage Tests (Source Mode), continued

Type	Temperature	Reading	Tolerance	Expanded Measurement Uncertainty
G	500°C	4844.8 μV	4843.3 μV to 4846.3 μV	
G	1200°C	18613.7 μV	18611.9 μV to 18615.5 μV	
G	2250°C	37731.6 μV	37729.4 μV to 37733.8 μV	
G	400°F	1075.5 μV	1074.1 μV to 1076.9 μV	
G	3500°F	32819.6 μV	32817.5 μV to 32821.7 μV	
G	4100°F	37863.9 μV	37861.7 μV to 37866.1 μV	
J-MN175	-105°C	-4836.3 μV	-4837.8 μV to -4834.8 μV	
J-MN175	0°C	0.0 μV	-1.4 μV to 1.4 μV	
J-MN175	1100°C	63792.2 μV	63789.5 μV to 63794.9 μV	
J-MN175	-200°F	-5760.2 μV	-5761.7 μV to -5758.7 μV	
J-MN175	32°F	0.0 μV	-1.4 μV to 1.4 μV	
J-MN175	2000°F	63406.5 μV	63403.8 μV to 63409.2 μV	
K-MN175	-200°C	-5891.4 μV	-5892.9 μV to -5889.9 μV	
K-MN175	0°C	0.0 μV	-1.4 μV to 1.4 μV	
K-MN175	1200°C	48838.2 μV	48835.8 μV to 48840.6 μV	
K-MN175	-250°F	-5066.8 μV	-5068.3 μV to -5065.3 μV	
K-MN175	32°F	0.0 μV	-1.4 μV to 1.4 μV	
K-MN175	1800°F	40580.9 μV	40578.7 μV to 40583.1 μV	
N-MN175	-175°C	-3701.5 μV	-3703.0 μV to -3700.0 μV	
N-MN175	0°C	0.0 μV	-1.4 μV to 1.4 μV	
N-MN175	1000°C	36255.5 μV	36253.4 μV to 36257.6 μV	
N-MN175	-350°F	-4101.6 μV	-4103.1 μV to -4100.1 μV	
N-MN175	32°F	0.0 μV	-1.4 μV to 1.4 μV	
N-MN175	1700°F	33411.1 μV	33409.0 μV to 33413.2 μV	

Ectron Model 1140A Calibration Test Report Thirty-day Specifications, ITS-90

Report Number _____

Thermocouple-voltage Tests (Source Mode), continued

Type	Temperature	Reading	Tolerance	Expanded Measurement Uncertainty
PL II	50°C	1574.7 μ V	1573.3 μ V to 1576.1 μ V	
PL II	700°C	29100.8 μ V	29098.8 μ V to 29102.8 μ V	
PL II	1300°C	52258.2 μ V	52255.8 μ V to 52260.6 μ V	
PL II	150°F	2096.5 μ V	2095.1 μ V to 2097.9 μ V	
PL II	1800°F	40836.0 μ V	40833.8 μ V to 40838.2 μ V	
PL II	2400°F	52763.4 μ V	52760.9 μ V to 52765.9 μ V	
R-MN175	0°C	0.0 μ V	-1.4 μ V to 1.4 μ V	
R-MN175	250°C	1923.4 μ V	1922.0 μ V to 1924.8 μ V	
R-MN175	1600°C	18848.9 μ V	18847.1 μ V to 18850.7 μ V	
R-MN175	32°F	0.0 μ V	-1.4 μ V to 1.4 μ V	
R-MN175	200°F	597.9 μ V	596.5 μ V to 599.3 μ V	
R-MN175	3000°F	19524.5 μ V	19522.7 μ V to 19526.3 μ V	
S-MN175	0°C	0.0 μ V	-1.4 μ V to 1.4 μ V	
S-MN175	300°C	2323.0 μ V	2321.6 μ V to 2324.4 μ V	
S-MN175	1700°C	17947.3 μ V	17945.5 μ V to 17949.1 μ V	
S-MN175	32°F	0.0 μ V	-1.4 μ V to 1.4 μ V	
S-MN175	1000°F	4609.5 μ V	4608.0 μ V to 4611.0 μ V	
S-MN175	3000°F	17353.3 μ V	17351.6 μ V to 17355.0 μ V	
T-MN175	-135°C	-4299.6 μ V	-4301.1 μ V to -4298.1 μ V	
T-MN175	0°C	0.0 μ V	-1.4 μ V to 1.4 μ V	
T-MN175	300°C	14861.9 μ V	14860.2 μ V to 14863.6 μ V	
T-MN175	-200°F	-4149.5 μ V	-4151.0 μ V to -4148.0 μ V	
T-MN175	32°F	0.0 μ V	-1.4 μ V to 1.4 μ V	
T-MN175	700°F	19097.4 μ V	19095.6 μ V to 19099.2 μ V	

Ectron Model 1140A Calibration Test Report Thirty-day Specifications, ITS-90

Report Number _____

Thermocouple-alloy Tests

Type E-MN175 Connected to	Reading	Tolerance	Expanded Measurement Uncertainty
Binding Posts	_____ μV	-2.9 μV to 2.9 μV	_____
Thermocouple Connector	_____ μV	-2.9 μV to 2.9 μV	_____

Output-current Test

Current at	Reading	Tolerance	Expanded Measurement Uncertainty
+1 V dc	_____ mA	50 mA to 100 mA	_____
-1 V dc	_____ mA	-50 mA to -100 mA	_____

Equipment Used:

Test Temperature _____

Test Relative Humidity _____

Next Calibration Due _____

Metrologist _____

Approved by _____

Ectron Model 1140A Calibration Test Report Six-month Specifications, ITS-90

Customer _____	Date _____
Address _____	Serial Number _____
_____	Report Number _____
_____	Other Identifier _____

Procedure Model 1140A Instruction Manual, [Section IX](#)

Linear-voltage Tests

Voltage	Source Reading	Meter Reading	Tolerance	Expanded Measurement Uncertainty
11.00000 V	V	V	10.999723 V to 11.000277 V	_____
-11.00000 V	V	V	-11.000277 V to -10.999723 V	_____
-10.00000 V	V	V	-10.000252 V to -9.999748 V	_____
10.00000 V	V	V	9.999748 V to 10.000252 V	_____
5.000000 V	V	V	4.999873 V to 5.000127 V	_____
-5.000000 V	V	V	-5.000127 V to -4.999873 V	_____
-2.500000 V	V	V	-2.500065 V to -2.499936 V	_____
2.500000 V	V	V	2.499936 V to 2.500065 V	_____
1.377000 V	V	V	1.3769636 V to 1.3770364 V	_____
-1.377000 V	V	V	-1.3770364 V to -1.3769636 V	_____
-1.373000 V	V	V	-1.3730363 V to -1.3729637 V	_____
1.373000 V	V	V	1.3729637 V to 1.3730363 V	_____
500.0000 mV	mV	mV	499.9855 mV to 500.0145 mV	_____
-500.0000 mV	mV	mV	-500.0145 mV to -499.9855 mV	_____
-88.0000 mV	mV	mV	-88.0042 mV to -87.9958 mV	_____
88.0000 mV	mV	mV	87.9958 mV to 88.0042 mV	_____
85.0000 mV	mV	mV	84.9959 mV to 85.0041 mV	_____
-85.0000 mV	mV	mV	-85.0041 mV to -84.9959 mV	_____
0.0000 mV	μV	μV	-2.0 μV to 2.0 μV	_____

Ectron Model 1140A Calibration Test Report Six-month Specifications, ITS-90

Report Number _____

Thermocouple-voltage Tests (Source Mode)

Type	Temperature	Reading	Tolerance	Expanded Measurement Uncertainty
B-MN175	400°C	786.5 μV	784.1 μV to 788.9 μV	
B-MN175	800°C	3153.6 μV	3151.1 μV to 3156.1 μV	
B-MN175	1600°C	11263.0 μV	11260.3 μV to 11265.7 μV	
B-MN175	500°F	317.1 μV	314.7 μV to 319.5 μV	
B-MN175	1215°F	2147.0 μV	2144.5 μV to 2149.5 μV	
B-MN175	3092°F	12432.5 μV	12429.8 μV to 12435.2 μV	
C	1100°C	20070.8 μV	20067.9 μV to 20073.7 μV	
C	1600°C	28242.8 μV	28239.7 μV to 28245.9 μV	
C	2300°C	36931.0 μV	36927.7 μV to 36934.3 μV	
C	1000°F	9392.8 μV	9390.2 μV to 9395.4 μV	
C	3000°F	28960.7 μV	28957.6 μV to 28963.8 μV	
C	4100°F	36548.0 μV	36544.7 μV to 36551.3 μV	
D	200°C	2602.0 μV	2599.5 μV to 2604.5 μV	
D	1700°C	31093.3 μV	31090.1 μV to 31096.5 μV	
D	2250°C	38854.8 μV	38851.4 μV to 38858.2 μV	
D	200°F	1058.0 μV	1055.6 μV to 1060.4 μV	
D	3200°F	32072.3 μV	32069.1 μV to 32075.5 μV	
D	4000°F	38350.5 μV	38347.1 μV to 38353.9 μV	
E-MN175	-175°C	-8121.1 μV	-8123.7 μV to -8118.5 μV	
E-MN175	0°C	0.0 μV	-2.4 μV to 2.4 μV	
E-MN175	950°C	72602.7 μV	72598.5 μV to 72606.9 μV	
E-MN175	-150°F	-5287.3 μV	-5289.8 μV to -5284.8 μV	
E-MN175	32°F	0.0 μV	-2.4 μV to 2.4 μV	
E-MN175	1400°F	57870.0 μV	57866.2 μV to 57873.8 μV	

Ectron Model 1140A Calibration Test Report Six-month Specifications, ITS-90

Report Number _____

Thermocouple-voltage Tests (Source Mode), continued

Type	Temperature	Reading	Tolerance	Expanded Measurement Uncertainty
G	500°C	4844.8 μ V	4842.3 μ V to 4847.3 μ V	
G	1200°C	18613.7 μ V	18610.8 μ V to 18616.6 μ V	
G	2250°C	37731.6 μ V	37728.3 μ V to 37734.9 μ V	
G	400°F	1075.5 μ V	1073.1 μ V to 1077.9 μ V	
G	3500°F	32819.6 μ V	32816.4 μ V to 32822.8 μ V	
G	4100°F	37863.9 μ V	37860.6 μ V to 37867.2 μ V	
J-MN175	-105°C	-4836.3 μ V	-4838.8 μ V to -4833.8 μ V	
J-MN175	0°C	0.0 μ V	-2.4 μ V to 2.4 μ V	
J-MN175	1100°C	63792.2 μ V	63788.2 μ V to 63796.2 μ V	
J-MN175	-200°F	-5760.2 μ V	-5762.7 μ V to -5757.7 μ V	
J-MN175	32°F	0.0 μ V	-2.4 μ V to 2.4 μ V	
J-MN175	2000°F	63406.5 μ V	63402.5 μ V to 63410.5 μ V	
K-MN175	-200°C	-5891.4 μ V	-5893.9 μ V to -5888.9 μ V	
K-MN175	0°C	0.0 μ V	-2.4 μ V to 2.4 μ V	
K-MN175	1200°C	48838.2 μ V	48834.6 μ V to 48841.8 μ V	
K-MN175	-250°F	-5066.8 μ V	-5069.3 μ V to -5064.3 μ V	
K-MN175	32°F	0.0 μ V	-2.4 μ V to 2.4 μ V	
K-MN175	1800°F	40580.9 μ V	40577.5 μ V to 40584.3 μ V	
N-MN175	-175°C	-3701.5 μ V	-3704.0 μ V to -3699.0 μ V	
N-MN175	0°C	0.0 μ V	-2.4 μ V to 2.4 μ V	
N-MN175	1000°C	36255.5 μ V	36252.2 μ V to 36258.8 μ V	
N-MN175	-350°F	-4101.6 μ V	-4104.1 μ V to -4099.1 μ V	
N-MN175	32°F	0.0 μ V	-2.4 μ V to 2.4 μ V	
N-MN175	1700°F	33411.1 μ V	33407.9 μ V to 33414.3 μ V	

Ectron Model 1140A Calibration Test Report Six-month Specifications, ITS-90

Report Number _____

Thermocouple-voltage Tests (Source Mode), continued

Type	Temperature	Reading	Tolerance	Expanded Measurement Uncertainty
PL II	50°C	1574.7 μV	1572.3 μV to 1577.1 μV	
PL II	700°C	29100.8 μV	29097.7 μV to 29103.9 μV	
PL II	1300°C	52258.2 μV	52254.5 μV to 52261.9 μV	
PL II	150°F	2096.5 μV	2094.0 μV to 2099.0 μV	
PL II	1800°F	40836.0 μV	40832.6 μV to 40839.4 μV	
PL II	2400°F	52763.4 μV	52759.7 μV to 52767.1 μV	
R-MN175	0°C	0.0 μV	-2.4 μV to 2.4 μV	
R-MN175	250°C	1923.4 μV	1921.0 μV to 1925.8 μV	
R-MN175	1600°C	18848.9 μV	18846.0 μV to 18851.8 μV	
R-MN175	32°F	0.0 μV	-2.4 μV to 2.4 μV	
R-MN175	200°F	597.9 μV	595.5 μV to 600.3 μV	
R-MN175	3000°F	19524.5 μV	19521.6 μV to 19527.4 μV	
S-MN175	0°C	0.0 μV	-2.4 μV to 2.4 μV	
S-MN175	300°C	2323.0 μV	2320.5 μV to 2325.5 μV	
S-MN175	1700°C	17947.3 μV	17944.5 μV to 17950.1 μV	
S-MN175	32°F	0.0 μV	-2.4 μV to 2.4 μV	
S-MN175	1000°F	4609.5 μV	4607.0 μV to 4612.0 μV	
S-MN175	3000°F	17353.3 μV	17350.5 μV to 17356.1 μV	
T-MN175	-135°C	-4299.6 μV	-4302.1 μV to -4297.1 μV	
T-MN175	0°C	0.0 μV	-2.4 μV to 2.4 μV	
T-MN175	300°C	14861.9 μV	14859.1 μV to 14864.7 μV	
T-MN175	-200°F	-4149.5 μV	-4152.0 μV to -4147.0 μV	
T-MN175	32°F	0.0 μV	-2.4 μV to 2.4 μV	
T-MN175	700°F	19097.4 μV	19094.5 μV to 19100.3 μV	

Ectron Model 1140A Calibration Test Report Six-month Specifications, ITS-90

Report Number _____

Thermocouple-alloy Tests

Type E-MN175 Connected to	Reading	Tolerance	Expanded Measurement Uncertainty
Binding Posts	_____ μV	-3.5 μV to 3.5 μV	_____
Thermocouple Connector	_____ μV	-3.5 μV to 3.5 μV	_____

Output-current Test

Current at			
+1 V dc	_____ mA	50 mA to 100 mA	_____
-1 V dc	_____ mA	-50 mA to -100 mA	_____

Equipment Used:

Test Temperature _____

Test Relative Humidity _____

Next Calibration Due _____

Metrologist _____

Approved by _____

Ectron Model 1140A Calibration Test Report One-year Specifications, ITS-90

Customer _____	Date _____
Address _____	Serial Number _____
_____	Report Number _____
_____	Other Identifier _____

Procedure Model 1140A Instruction Manual, [Section IX](#)

Linear-voltage Tests

Voltage	Source Reading	Meter Reading	Tolerance	Expanded Measurement Uncertainty
11.00000 V	V	V	10.999668 V to 11.000332 V	_____
-11.00000 V	V	V	-11.000332 V to -10.999668 V	_____
-10.00000 V	V	V	-10.000302 V to -9.999698 V	_____
10.00000 V	V	V	9.999698 V to 10.000302 V	_____
5.000000 V	V	V	4.999848 V to 5.000152 V	_____
-5.000000 V	V	V	-5.000152 V to -4.999848 V	_____
-2.500000 V	V	V	-2.500078 V to -2.499922 V	_____
2.500000 V	V	V	2.499922 V to 2.500078 V	_____
1.377000 V	V	V	1.3769562 V to 1.3770438 V	_____
-1.377000 V	V	V	-1.3770438 V to -1.3769562 V	_____
-1.373000 V	V	V	-1.3730437 V to -1.3729563 V	_____
1.373000 V	V	V	1.3729563 V to 1.3730437 V	_____
500.0000 mV	mV	mV	499.9825 mV to 500.0175 mV	_____
-500.0000 mV	mV	mV	-500.0175 mV to -499.9825 mV	_____
-88.0000 mV	mV	mV	-88.0051 mV to -87.9949 mV	_____
88.0000 mV	mV	mV	87.9949 mV to 88.0051 mV	_____
85.0000 mV	mV	mV	84.9950 mV to 85.0050 mV	_____
-85.0000 mV	mV	mV	-85.0050 mV to -84.9950 mV	_____
0.0000 mV	μV	μV	-2.5 μV to 2.5 μV	_____

Ectron Model 1140A Calibration Test Report One-year Specifications, ITS-90

Report Number _____

Thermocouple-voltage Tests (Source Mode)

Type	Temperature	Reading	Tolerance	Expanded Measurement Uncertainty
B-MN175	400°C	786.5 μV	783.6 μV to 789.4 μV	
B-MN175	800°C	3153.6 μV	3150.6 μV to 3156.6 μV	
B-MN175	1600°C	11263.0 μV	11259.8 μV to 11266.2 μV	
B-MN175	500°F	317.1 μV	314.2 μV to 320.0 μV	
B-MN175	1215°F	2147.0 μV	2144.0 μV to 2150.0 μV	
B-MN175	3092°F	12432.5 μV	12429.2 μV to 12435.8 μV	
C	1100°C	20070.8 μV	20067.3 μV to 20074.3 μV	
C	1600°C	28242.8 μV	28239.1 μV to 28246.5 μV	
C	2300°C	36931.0 μV	36927.0 μV to 36935.0 μV	
C	1000°F	9392.8 μV	9389.6 μV to 9396.0 μV	
C	3000°F	28960.7 μV	28956.9 μV to 28964.5 μV	
C	4100°F	36548.0 μV	36544.0 μV to 36552.0 μV	
D	200°C	2602.0 μV	2599.0 μV to 2605.0 μV	
D	1700°C	31093.3 μV	31089.5 μV to 31097.1 μV	
D	2250°C	38854.8 μV	38850.7 μV to 38858.9 μV	
D	200°F	1058.0 μV	1055.1 μV to 1060.9 μV	
D	3200°F	32072.3 μV	32068.4 μV to 32076.2 μV	
D	4000°F	38350.5 μV	38346.4 μV to 38354.6 μV	
E-MN175	-175°C	-8121.1 μV	-8124.2 μV to -8118.0 μV	
E-MN175	0°C	0.0 μV	-2.9 μV to 2.9 μV	
E-MN175	950°C	72602.7 μV	72597.6 μV to 72607.8 μV	
E-MN175	-150°F	-5287.3 μV	-5290.4 μV to -5284.2 μV	
E-MN175	32°F	0.0 μV	-2.9 μV to 2.9 μV	
E-MN175	1400°F	57870.0 μV	57865.4 μV to 57874.6 μV	

Ectron Model 1140A Calibration Test Report One-year Specifications, ITS-90

Report Number _____

Thermocouple-voltage Tests (Source Mode), continued

Type	Temperature	Reading	Tolerance	Expanded Measurement Uncertainty
G	500°C	4844.8 μV	4841.8 μV to 4847.8 μV	
G	1200°C	18613.7 μV	18610.2 μV to 18617.2 μV	
G	2250°C	37731.6 μV	37727.6 μV to 37735.6 μV	
G	400°F	1075.5 μV	1072.6 μV to 1078.4 μV	
G	3500°F	32819.6 μV	32815.7 μV to 32823.5 μV	
G	4100°F	37863.9 μV	37859.9 μV to 37867.9 μV	
J-MN175	-105°C	-4836.3 μV	-4839.3 μV to -4833.3 μV	
J-MN175	0°C	0.0 μV	-2.9 μV to 2.9 μV	
J-MN175	1100°C	63792.2 μV	63787.4 μV to 63797.0 μV	
J-MN175	-200°F	-5760.2 μV	-5763.3 μV to -5757.1 μV	
J-MN175	32°F	0.0 μV	-2.9 μV to 2.9 μV	
J-MN175	2000°F	63406.5 μV	63401.7 μV to 63411.3 μV	
K-MN175	-200°C	-5891.4 μV	-5894.5 μV to -5888.3 μV	
K-MN175	0°C	0.0 μV	-2.9 μV to 2.9 μV	
K-MN175	1200°C	48838.2 μV	48833.8 μV to 48842.6 μV	
K-MN175	-250°F	-5066.8 μV	-5069.9 μV to -5063.7 μV	
K-MN175	32°F	0.0 μV	-2.9 μV to 2.9 μV	
K-MN175	1800°F	40580.9 μV	40576.8 μV to 40585.0 μV	
N-MN175	-175°C	-3701.5 μV	-3704.5 μV to -3698.5 μV	
N-MN175	0°C	0.0 μV	-2.9 μV to 2.9 μV	
N-MN175	1000°C	36255.5 μV	36251.5 μV to 36259.5 μV	
N-MN175	-350°F	-4101.6 μV	-4104.6 μV to -4098.6 μV	
N-MN175	32°F	0.0 μV	-2.9 μV to 2.9 μV	
N-MN175	1700°F	33411.1 μV	33407.2 μV to 33415.0 μV	

Ectron Model 1140A Calibration Test Report One-year Specifications, ITS-90

Report Number _____

Thermocouple-voltage Tests (Source Mode), continued

Type	Temperature	Reading	Tolerance	Expanded Measurement Uncertainty
PL II	50°C	1574.7 μ V	1571.8 μ V to 1577.6 μ V	
PL II	700°C	29100.8 μ V	29097.0 μ V to 29104.6 μ V	
PL II	1300°C	52258.2 μ V	52253.7 μ V to 52262.7 μ V	
PL II	150°F	2096.5 μ V	2093.5 μ V to 2099.5 μ V	
PL II	1800°F	40836.0 μ V	40831.9 μ V to 40840.1 μ V	
PL II	2400°F	52763.4 μ V	52758.9 μ V to 52767.9 μ V	
R-MN175	0°C	0.0 μ V	-2.9 μ V to 2.9 μ V	
R-MN175	250°C	1923.4 μ V	1920.4 μ V to 1926.4 μ V	
R-MN175	1600°C	18848.9 μ V	18845.4 μ V to 18852.4 μ V	
R-MN175	32°F	0.0 μ V	-2.9 μ V to 2.9 μ V	
R-MN175	200°F	597.9 μ V	595.0 μ V to 600.8 μ V	
R-MN175	3000°F	19524.5 μ V	19521.0 μ V to 19528.0 μ V	
S-MN175	0°C	0.0 μ V	-2.9 μ V to 2.9 μ V	
S-MN175	300°C	2323.0 μ V	2320.0 μ V to 2326.0 μ V	
S-MN175	1700°C	17947.3 μ V	17943.9 μ V to 17950.7 μ V	
S-MN175	32°F	0.0 μ V	-2.9 μ V to 2.9 μ V	
S-MN175	1000°F	4609.5 μ V	4606.5 μ V to 4612.5 μ V	
S-MN175	3000°F	17353.3 μ V	17349.9 μ V to 17356.7 μ V	
T-MN175	-135°C	-4299.6 μ V	-4302.6 μ V to -4296.6 μ V	
T-MN175	0°C	0.0 μ V	-2.9 μ V to 2.9 μ V	
T-MN175	300°C	14861.9 μ V	14858.6 μ V to 14865.2 μ V	
T-MN175	-200°F	-4149.5 μ V	-4152.5 μ V to -4146.5 μ V	
T-MN175	32°F	0.0 μ V	-2.9 μ V to 2.9 μ V	
T-MN175	700°F	19097.4 μ V	19093.9 μ V to 19100.9 μ V	

Ectron Model 1140A Calibration Test Report One-year Specifications, ITS-90

Report Number _____

Thermocouple-alloy Tests

Type E-MN175 Connected to	Reading	Tolerance	Expanded Measurement Uncertainty
Binding Posts	_____ μV	-4.1 μV to 4.1 μV	_____
Thermocouple Connector	_____ μV	-4.1 μV to 4.1 μV	_____

Output-current Test

Current at	Reading	Tolerance	Expanded Measurement Uncertainty
+1 V dc	_____ mA	50 mA to 100 mA	_____
-1 V dc	_____ mA	-50 mA to -100 mA	_____

Equipment Used:

Test Temperature _____

Test Relative Humidity _____

Next Calibration Due _____

Metrologist _____

Approved by _____

APPENDIX B

THERMOCOUPLE CALIBRATION PROCEDURE

GENERAL

This procedure describes how to calibrate a thermocouple for use with the Model 1140A during its alignment and calibration. It involves immersing the cold junction in an ice bath and the hot junction in a stable bath set to approximately 26°C. This temperature is chosen because it is the operating temperature of the thermocouple connector and the binding posts of the Model 1140A.¹⁶ Once the error of the thermocouple, if any, has been determined, the junction made is clipped open so that the thermocouple can be connected to the Model 1140A for alignment or calibration.

EQUIPMENT REQUIRED

- Digital multimeter (DMM), Hewlett Packard Model 3458A or equivalent.
- Ice-point bath for thermocouple cold junctions with an expanded uncertainty (k=2) of $0^{\circ}\text{C} \pm 0.006^{\circ}\text{C}$ or better.
- Stirred bath, Hart 7025 or equivalent. An equivalent must be settable to +26°C.
- Platinum Resistance Thermometer (PRT) with expanded uncertainty (k=2) of $\pm 0.006^{\circ}\text{C}$ or better at 26°C and with its resistance table for temperatures of 20°C to 30°C.
- Special Limits of Error (SLE) thermocouple wire of the desired type (typically Type E or T).

PROCEDURE

1. Using Special Limits of Error (SLE) thermocouple wire, fashion the thermocouple such that the hot junction is made by welding (or twisting and soldering) the pair of thermoelements together. If soldering, the overall length of the portion twisted and soldered should be no more than 0.25 inches. The cold junction is made with terminations to copper wire inserted in the ice-point bath. The thermocouple is calibrated with the hot junction at +26°C. See Figure B-1 for the correct setup.
2. Set the stirred bath to 26°C and allow it to stabilize.
3. Mechanically fix the hot junction of the thermocouple under test at the midpoint of the sensing portion of the PRT using a suitable nonconductive tie. Ensure that any bare thermocouple wires do not touch the PRT sheath.
4. Place the PRT and the attached thermocouple hot junction in the stirred bath and allow it to stabilize.
5. The DMM can be alternately connected to the PRT and the thermocouple copper connections, or if two DMMs are available the readings may be monitored simultaneously.

¹⁶ Due to internal heating in the instrument, the temperature within the Model 1140A's terminals is typically about 3°C above the ambient lab temperature.

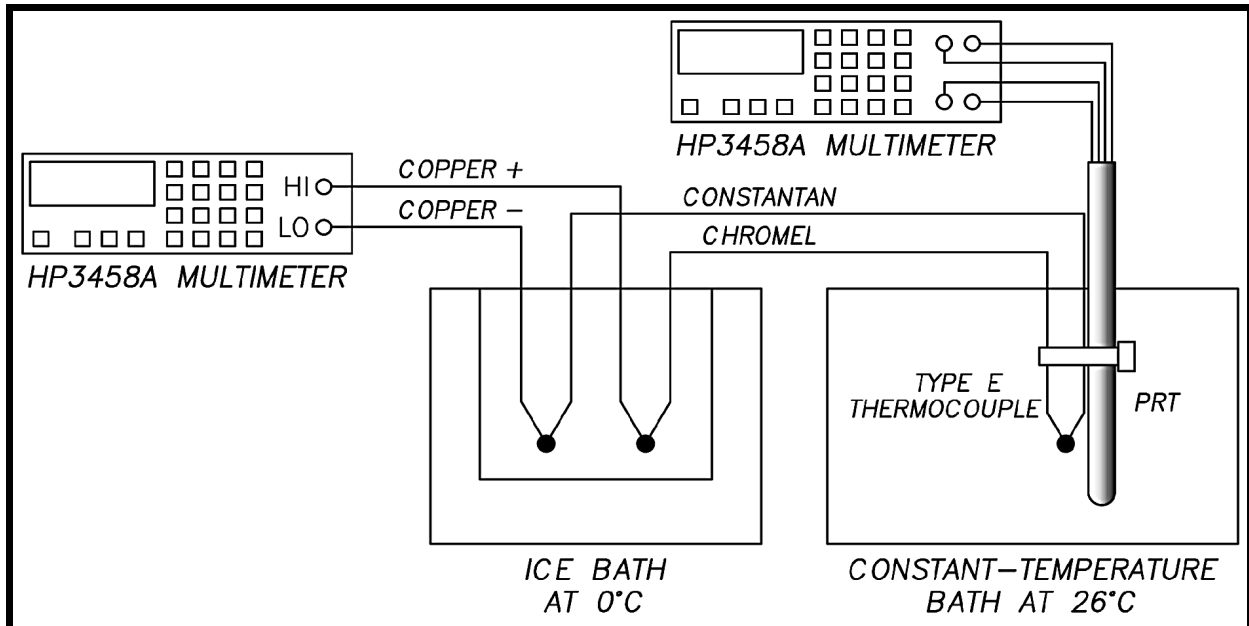

Figure B-1: Type E Thermocouple Calibration Setup

6. When the temperature is stable, record the PRT resistance using the digital multimeter.
7. Record the output voltage of the thermocouple using the digital multimeter.
8. Convert the resistance reading to temperature using calibration constants for the PRT or by linear interpolation if temperature tables are available for the PRT.
9. Using the polynomial equations from NIST *Monograph 175* for the appropriate thermocouple type, determine the expected output voltage of the thermocouple at the PRT temperature.
10. Calculate the error for this thermocouple at 26°C as follows:
 (Thermocouple voltage from Step 7) – (Expected voltage from Step 9)
11. Affix a tag to the thermocouple stating the error. Be sure to include the polarity of the error.
12. After calibration, cut off the welded or soldered hot junction of the thermocouple (do not cut the copper connections from the thermoelements). The part cut off should be minimal so that the composition or portion of the thermoelements available for future use is as close as possible to the composition of the thermoelements that made up the hot junction.

INDEX

Numeric

1120 emulation, see [Model 1120 Remote Emulation](#).

1140A, description of, [1](#)

A

Ac operation, [16](#)
Specifications, [5](#)

Alignment, [65](#)

Enabling, [35](#)

Failure, [21](#)

Switch, [35](#)

Terminal, [67](#)

Thermocouple alloy corrections, [68](#)

Troubleshooting, see the separate Service Manual.

Voltage, [66](#)

“Alignment switch on” message, [20](#)

Alloy wire, [18](#)

Selecting, [25](#)

Analog assembly

Hardware, [62](#)

Applications, [38](#)

Arrow keys, [17](#)

Autozero, [26](#)

Applications, [42](#)

B

Backlight, see [Display](#).

Battery

Hardware, [63](#)

Messages, see [Messages](#).

Operation, [39](#)

Recharge, [16](#)

Replacement of battery, see the separate Service Manual.

Binding posts

Applications, [39](#)

Selecting, [25](#)

Button, power, [15](#)

Buttons and controls, [15](#)

C

Calibration procedure, [69](#)

Linear-voltage tests in meter mode, [71](#)

Linear-voltage tests in source mode, [71](#)

Linear-voltage-tests setup, [70](#)

Output-current test, [75](#)

Preliminary setup, [70](#)

Thermocouple alloy tests, [73](#)

Thermocouple voltage tests, [72](#)

Calibration test report, [76](#)

Calibration of thermocouple, [92](#)

Charging the battery, [16](#)

Connections, [39](#)

Contrast, display, [32](#)

Copper offset units, setting, [26](#)

Copper voltage offset, setting, [26](#)

Copper wire, [18](#)

Selecting, [25](#)

Creating a new file, [27](#)

D

Data logging

Downloading data, [31](#)

Menu, [30](#)

Setting the logging interval, [31](#)

Starting, [31](#)

Viewing logged data, [31](#)

Viewing logged instrument setup, [31](#)

Date, setting, [35](#)

Dc operation, [16](#)

Specifications, [5](#)

Default values, resetting the instrument to, [36](#)

Deleting a file, [28](#)

Deleting a sequence, [29](#)

Deleting a step in a sequence, [29](#)

Description, overall, [1](#)

Diagnostic messages, see [Messages](#).

Diagnostics menu, [36](#)

Display
 Backlight brightness, 32
 Backlight mode, 32
 Backlight time, 32
 Contrast, 32
 Menu, 31
 Messages, see [Messages](#).
 Downloading data, 30, 31
 Drivers, 13

E

Emulation, 1120, see [Model 1120 Remote Emulation](#).
 Encoder (large knob), 17
 Enter key, 16
 Error codes, remote, 53
 Error messages, see [Messages](#).
 Escape key, 16
 Ethernet setup, 33

F

Files
 Creating new, 27
 Deleting, 28
 Opening, 27
 Renaming, 27
 Saving, 27
 Saving as, 27

Firmware,
 Theory, 62
 Version, 37

Front-panel assembly, hardware, 62
 Front-panel controls, 15
 Front-panel display, see [Display](#).
 Functions, 38

G

GPIB setup, 33
 Grounding, 41
 Guard bands, 43
 Guard terminals, shield connections, 41

H

Hardware implementation, 62
 Analog assembly, 62
 Battery, 63
 Front-panel assembly, 62
 Power-supply assembly, 64

I

Inserting a sequence step, 28
 Installation, 13
 Instruction manual, overview, 2
 Instrument mode (source/meter), 38
 Menu, 24
 Setting, 24
 Interface board errors, 22
 Interference, shielding against, 41
 IPTS-68, 41
 Selecting, 25
 ITS-90, 41
 Selecting, 25

K

Keys, 15
 Arrow, 17
 Enter, 16
 Escape, 16
 Keypad, 17
 Menu, 16
 Testing, 36

Knob (encoder), 17

L

LCD display, see [Display](#).
 LCD test, 37
 Logging interval, setting, 31

M

Main display (operating screen), 17
 Main menu, 22
 Maintenance menu, 35
 Manual, overview, 2
 Manual sequence stepping, 29
 Material, wire, 18
 Setting, 25

Index

- Memory menu, 26
 - Menu key, 16
 - Menus, 22
 - Data logging, 30
 - Diagnostics, 36
 - Display, 31
 - Instrument mode, 24
 - Maintenance, 35
 - Memory, 26
 - Output, 25
 - Remote, 32
 - Sequence, 28
 - Thermocouple, 23
 - Messages, 20
 - Alignment failure, 21
 - Alignment switch on, 20
 - Autozero (AZ), 26, 42
 - Batt flt, 21
 - Charged, 21
 - Charging, 20
 - Interface board errors, 22
 - Low batt, 21
 - Other, 21
 - Out of range, 20
 - Overload, 20
 - Standby, 20
 - System errors, 21
 - Temp flt, 21
 - Meter mode, 38
 - Selecting, 24
 - Specifications, 5
 - Mini-three-pin thermocouple connector, applications, 39
 - Mode
 - Instrument (source and measure), 18, 24
 - Output, 24
 - Standby, 15, 20
 - Model 1120 Remote Emulation, 32, 55
 - Background, 55
 - Command processing, 56
 - Default thermocouple type at power-up, 56
 - Errors, 58
 - GPIB parallel and serial poll, 56
 - Limitations, 55
 - Local lockout, 56
 - Meter and source modes in, 57
 - Numeric editing, 56
 - Operation, 57
 - Packet delimiter, 56
 - Standby, 57
- ## N
- Noise, shielding against, 41
 - Numeric keypad, 17
- ## O
- Offset, 18
 - Applications, 41
 - Copper voltage, 26
 - Thermocouple, 23
 - Opening a file, 27
 - Operate (vs. standby), 15, 20
 - Operating screen, 17
 - Control, 18
 - Operation, 15
 - Remote, 44
 - “Out of range” message, 20
 - Output
 - Impedance, 42
 - Menu, 25
 - Mode, setting, 24
 - Specifications, 4
 - “Overload” message, 20
- ## P
- Packing for shipment, 13
 - Polarity of thermocouple wires, 40
 - Power, 15
 - Power-supply assembly hardware, 64
 - Problems, troubleshooting, see the separate Service Manual.
- ## R
- Recharge, battery, 16
 - Reference-junction temperature, 18, 23
 - Setting, 23
 - Units, setting, 23
 - Remote interface
 - Commands and queries, 46

- Drivers, 13
- Downloading data via, 31
- Menu, 32
- Operation, 44
- Renaming a file, 27
- Repair, see the separate Service Manual.
- Repeating a sequence
 - Manual, 29
 - Timed, 29
- Report, calibration, 76
- Reset instrument to default values, 36
- Resolution limit
 - Temperature, setting, 24
 - Voltage, setting, 25

S

- Saving a file, 27
- Saving a file as, 27
- Screen, see [Display](#).
- Screen messages, see [Messages](#).
- Sequence menu, 28
- Sequences, 28
 - Deleting, 29
 - Deleting a step, 29
 - Inserting a step, 28
 - Moving a step, 28
 - Repeating, manual, 29
 - Repeating, timed, 29
 - Stepping and stepping time, 29
 - Viewing/starting, 28
- Shielding, 41
- Shipment contents, 13
- Source mode, 38
 - Selecting, 24
 - Specifications, 4
- Specifications, 4
 - General, 5
 - Meter mode, 5
 - Source mode, 4
 - Thermocouple accuracy, 6
- Standby, 15, 20, 35
- Starting a sequence, 28
- Step time, sequence, 29
- Stepping, sequence, 29
- Storage, temperature range, 6

- System errors, 21
- System temperature units, setting, 24
- System voltage units, setting, 24

T

- TC connector, applications, 39
- Temperature
 - Output, selecting, 24
 - Reference-junction, see [Reference-junction temperature](#).
 - Resolution limit, setting, 24
 - Scale, setting, 25
 - Units, setting, 24
 - Variation, ambient, 40
- Terminals
 - Alignment, 67
 - Choosing, 40
 - Corrections, 68
 - Guard, shielding, 41
 - Setting, 25
- Test report, 76
- Theory of operation, 59
- Thermocouple
 - Accuracy specifications, 6
 - Calibration procedure, 92
 - Connector, 25, 40
 - Corrections, 68
 - Menu, 23
 - Offset, 18, 23
 - Type, setting, 23
 - Wires, polarity, 40
- Time, setting, 35
- Timed sequence stepping, 29
- Troubleshooting, see the separate Service Manual.

U

- Unpacking, 13
- USB driver, 13

V

- Viewing logged data, 31
- Viewing logged instrument setup, 31
- Viewing/starting a sequence, 28

Index

Voltage

Alignment, [66](#)

Resolution limit, setting, [25](#)

Offset, setting, [26](#)

Output, selecting, [24](#)

Units, system, [24](#)

W

Wire material, setting, [25](#)

Z

Zeroing, see [Autozero](#).